



Rd-01serial communication protocol

Version V1.0.0

Copyright ©2023

Content

1. Introduction of communication interface	4
1.1. Pin definition and wiring	4
1.2. Configuration parameters and parameter description	4
2. Communication protocol	6
2.1. Protocol format	6
2.1.1. Protocol Data Format	6
2.1.2. Command protocol frame format	6
2.2. Send command with ACK	7
2.2.1. Enable configuration command mode。	7
2.2.2. End configuration command	7
2.2.3. Maximum range gate and no human duration parameter configuration command	8
2.2.4. Read parameter command	8
2.2.5. Enabling the engineering mode command	9
2.2.6. Close the engineering mode command	10
2.2.7. Distance gate sensitivity configuration command	10
2.3. Radar data output protocol	11
2.3.1. Report the data frame format	11
2.3.2. Target data composition	12
2.4. Radar command configuration mode	13
2.4.1. Radar command configuration step	13
2.4.2. Attentions for radar configuration	14
3. Contact us	15
Disclaimer and copyright notice	16
Notice	16
Important statement	17

1. Introduction of communication interface

1.1. Pin definition and wiring

Rd-01 module is connected to a total of 12 pins,as shown in the module pin diagram, the pin function definition table is the interface definition.

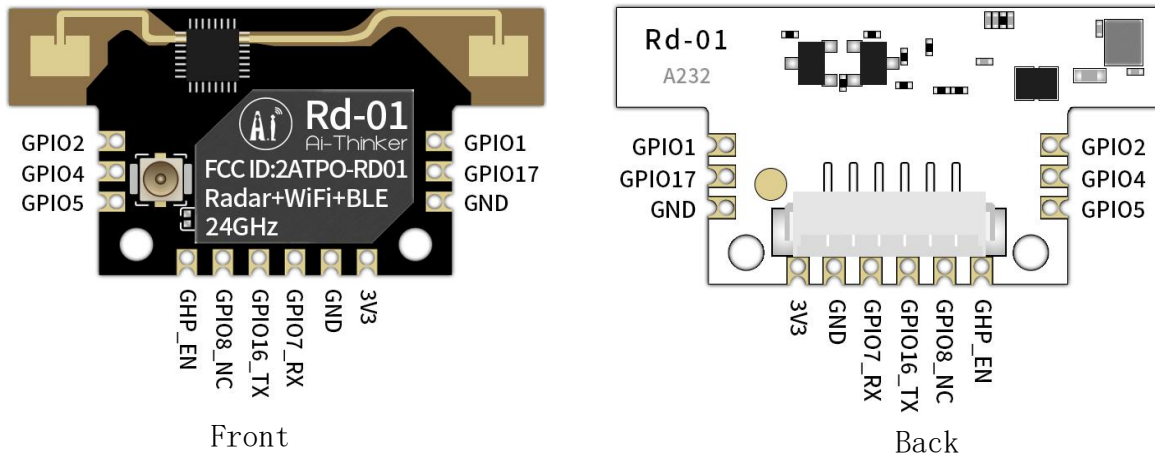

Figure1 Module pin diagram

Table 1 Rd-01connected to the TTL

Rd-01	USB to TTL
3.3V	3.3V
GND	GND
GPIO7_RX	TXD
GPIO16_TX	RXD
CHP_EN	RTS

1.2. Configuration parameters and parameter description

Users can modify the configuration parameters of the module through the serial port of Rd-01 to adapt to different application requirements. The configurable radar detection parameters are

shown in Table 2.

Table 2 Rd-01 configuration parameters

Parameters name	Available range	Default configure	Description
Maximum detection distance gate	2~8	8	75cm/range gate
Target disappearance delay time	0~65535	5	Unit/Second
Motion sensitivity	1~100	0~1 range gate: 50 2~5 range gate: 40 6~8 range gate: 30	
Motionless sensitivity	1~100	0~1 range gate: 0 2~5 range gate: 40 6~8 range gate: 15	The stationary part 0~1 distance gate does not participate in the judgment by default

■ The farthest detection distance

Set the maximum detectable distance where only the human target present within the longest distance will be detected and output. Set in distance gates, up to 8 distance gates, with configured distance resolution (0.2m or 0.75m per distance gate). Including the longest range gate of motion detection and the longest range gate of stationary detection, the range is 1~8, for example, the longest range gate is set to 2, the distance resolution is 0.75m, only within 1.5m can effectively detect and output the results.

■ Sensitivity

The target presence is determined only when the detected target energy value (range 0~100) is greater than the sensitivity value, otherwise it is ignored. The sensitivity value can be set in the range from 0 to 100. Each distance gate can be independently set with sensitivity, which can accurately adjust the detection within different distance range, local accurate detection or filtering of interference sources in specific areas. In addition, if the sensitivity of a certain distance gate is set to 100, the effect of not identifying the target under this distance gate can be achieved. For example, if the sensitivity of the distance gate 3 and 4 is set to 20, and the sensitivity of other distance gates is set to 100, and the distance resolution is 0.75m, only the human body within the distance module 2.25~3.75m can be detected.

■ No one duration time

In the results of output from someone to unmanned, it will report someone for a period of time.

If the radar continues to be unmanned during this period, the radar will report unmanned; if the radar detects someone during this period, refresh this time, unit seconds. It is equivalent to no delay time. After a person leaves, no one is kept beyond this duration before the output state becomes unmanned.

2. Communication protocol

This communication protocol is mainly separated from the visualization tool for secondary development of the user use. Rd-01 communicates with the outside world through a serial port (TTL level). Data output and parameter configuration commands of the radar are performed under this protocol. The default port rate of the radar serial port is 256000, with 1 stop bit and no parity bit.

2.1. Protocol format

2.1.1. Protocol Data Format

The serial port data communication of Rd-01 uses a small end format, and all data in the following table are hexadecimal.

2.1.2. Command protocol frame format

The radar configuration command and ACK command formats defined by the protocol are shown in Tables 3 to Table 6.

Table 3 Send command protocol frame format

Frame header	Intra-frame data length	Intra-frame data	End of frame
FD FC FB FA	2bytes	See table 4	04 03 02 01

Table 4 send intra-frame data format

Command word (2 bytes)	Command value (Nbytes)
------------------------	------------------------

Table 5 ACK command protocol frame format

Frame header	Intra-frame data length	Intra-frame data	End of frame
FD FC FB FA	2 bytes	Table 6	04 03 02 01

Table 6 ACK intra-frame data format

Send command word 0x0100 (2bytes)	Return value (N bytes)
-----------------------------------	------------------------

2.2. Send command with ACK

2.2.1. Enable configuration command mode。

Any other command issued to the radar must not be executed until this order is issued, otherwise it is invalid.

Command word:0x00FF

Command value:0x0001

Return value: 2 bytes ACK status (0 success, others value is failure) + 2 bytes protocol version (0x0001) + 2 bytes buffer size (0x0040)

Send data:

FD FC FB FA	04 00	FF 00	01 00	04 03 02 01
-------------	-------	-------	-------	-------------

Radar ACK(Success):

FD FC FB FA	08 00	FF 01	00 00	01 00	40 00	04 03 02 01
-------------	-------	-------	-------	-------	-------	-------------

2.2.2. End configuration command

End configuration command, Radar resumes working mode after execution. If you need to issue other commands again, you need to send the enable configuration command first.

Command word: 0x00FE

Command value: none

Return value: 2bytes ACK status (0 success, others value is failure)

Send data:

FD FC FB FA	02 00	FE 00	04 03 02 01
-------------	-------	-------	-------------

RadarACK(Success):

FD FC FB FA	04 00	FE 01	00 00	04 03 02 01
-------------	-------	-------	-------	-------------

2.2.3. Maximum range gate and no human duration parameter configuration command

This command sets the maximum radar detection range gate (motion & still) (configuration range 2-8) and the unmanned duration parameter (configuration range 0 to 65535 seconds). Please refer to Table 7 for the specific parameter words.

Command word: 0x0060

Command value: 2 bytes maximum motion distance gate + 4 bytes maximum motion distance gate parameter + 2 bytes maximum static distance gate + 4 bytes maximum static distance gate parameter + 2 bytes unmanned duration + 4 bytes unmanned duration parameter
 Return value: 2-byte ACK status (0 success, 1 failed)

Table 7 0x0060 Protocol parameter word

Parameter name	Parameter word
Maximum movement distance gate	0x0000
Maximum stationary distance gate	0x0001
No human duration time	0x0002

Send data: Maximum distance gate 8 (motion & motionless), unmanned duration of 5 seconds

FD FC FB FA	14 00	60 00	00 00	08 00 00 00	01 00	08 00 00 00	02 00	05 00 00 00	04 03 02 01
-------------	-------	-------	-------	-------------	-------	-------------	-------	-------------	-------------

Radar ACK(success):

FD FC FB FA	04 00	60 01	00 00	04 03 02 01
-------------	-------	-------	-------	-------------

2.2.4. Read parameter command

This command reads the current configuration parameters of the radar

Command word: 0x0061

Command value: none

Return value: 2 bytes ACK state (0 success, 1 failed) + header (0xAA) + maximum distance door N (0x08) + configuration maximum motion distance door + configuration maximum static distance door + distance door 0 motion sensitivity (1 byte) +... +, distance door N motion sensitivity (1 byte) + distance door 0 static sensitivity 1 byte) +... + distance door N static sensitivity (1 byte) + no duration (2 bytes)

Send data:

FD FC FB FA	02 00	61 00	04 03 02 01
-------------	-------	-------	-------------

Radar ACK: (success, maximum distance gate 8, configuration of motion distance gate 8, stationary distance gate 8,0~8 motion sensitivity 20,0~8 stationary sensitivity 25, unmanned duration of 5 seconds)

Byte 1-4	Byte 5,6	Byte 7,8	Byte 9,10	Byte 11	Byte 12	Byte 13	Byte 14	Byte 15	Byte 16	Byte 17	Byte 18
FD FC FB FA	1C 00	61 01	00 00	AA	08	08	08	14	14	14	14
Byte 19	Byte 20	Byte 21	Byte 22	Byte 23	Byte 24	Byte 25	Byte 26	Byte 27	Byte 28	Byte 29	Byte 30
14	14	14	14	14	14	19	19	19	19	19	19
Byte 31	Byte 32	Byte 33,34	Byte 35-38								
19	19	05 00	04 03 02 01								

2.2.5. Enabling the engineering mode command

This command turns on the radar engineering mode. After the engineering mode is opened, each distance gate energy value will be added to the radar reported data. Please refer to 2.3.2 Target data composition for detailed format. After the module is powered on, the engineering mode is off by default, and this configuration value is lost.

Command word: 0x0062

Command value: none

Return value: 2 bytes ACK status (0 success, 1 failed)

Send data:

FD FC FB FA	02 00	62 00	04 03 02 01
-------------	-------	-------	-------------

Radar ACK(success):

FD FC FB FA	04 00	62 01	00 00	04 03 02 01
-------------	-------	-------	-------	-------------

2.2.6. Close the engineering mode command

This command turns off the radar engineering mode. After shutdown, please refer to 2.3.2 Target data composition for radar reported data format.

Command word: 0x0063

Command value: none

Return value: 2 bytes ACK status (0 success, 1 failed)

Send data:

FD FC FB FA	02 00	63 00	04 03 02 01
-------------	-------	-------	-------------

Radar ACK(success):

FD FC FB FA	04 00	63 01	00 00	04 03 02 01
-------------	-------	-------	-------	-------------

2.2.7. Distance gate sensitivity configuration command

This command configures the sensitivity of the distance gate. This protocol supports both separate configuration of each distance gate and all distance gates into a uniform value. If all the distance gate sensitivity is set to the same value, the distance gate value should be set to 0xFFFF.

Command word: 0x0064

Command value: 2 bytes distance gate word + 4 bytes distance gate value + 2 bytes motion sensitivity word + 4 bytes motion sensitivity value + 2 bytes static sensitivity word + 4 bytes static sensitivity value

Return value: 2 bytes ACK status (0 success, 1 failed)

Parameter name	Parameter word
Range gate	0x0000
Range gate	0x0001
Static sensitivity word	0x0002

Send data: configure the motion sensitivity 40 and the stationary sensitivity 40 for the distance gate 3

FD FC FB FA	14 00	64 00	00 00	03 00 00 00	01 00	28 00 00 00	02 00	28 00 00 00	04 03 02 01
-------------	-------	-------	-------	-------------	-------	-------------	-------	-------------	-------------

Radar ACK (success) :

FD FC FB FA	04 00	64 01	00 00	04 03 02 01
-------------	-------	-------	-------	-------------

Send data: configure motion sensitivity 40 and stationary sensitivity 40 for all distance gates

FD FC FB FA	14 00	64 00	00 00	FF FF 00 00	01 00	28 00 00 00	02 00	28 00 00 00	04 03 02 01
-------------	-------	-------	-------	-------------	-------	-------------	-------	-------------	-------------

Radar ACK (success) :

FD FC FB FA	04 00	64 01	00 00	04 03 02 01
-------------	-------	-------	-------	-------------

2.3. Radar data output protocol

Rd-01 outputs the radar detection result through the serial port, and outputs the basic information of the target by default, including the target state, motion energy value, stationary energy value, motion distance, stationary distance and other information. If the radar is configured in engineering mode, the radar will output additional distance gate energy values (motion & stationary). The radar data is output in the specified frame format.

2.3.1. Report the data frame format

The radar report message frame format defined by the protocol is shown in Tables 8 and 9. The reported data type values are defined in Table 10

Table8 Report the data frame format

Frame header	Intra-frame data length	Intra-frame data	End of frame
F4 F3 F2 F1	2 bytes	Table 9	F8 F7 F6 F5

Table9 Intra-frame data frame format

Data type	Header	Target data	End of Frame	Check
1byte(table 10)	0xAA	Table 11,13	0x55	0x00

Table10 Data type description

Data type value	Description
0x01	Engineering mode data
0x02	Target basic information and data

2.3.2. Target data composition

The target data content reported by the radar will change according to the working mode of the radar. In normal working mode, the radar will output the basic information data of the target by default; when configured in engineering mode, the radar will add the energy value information of each distance gate after the basic information data of the target. Therefore, the basic information of the target will always be output in the radar reported data, while the distance gate energy value information will be output only after the command enabling. Under normal operation mode, the composition of target data reported by radar is shown in Table 11, and the definition of target state value is shown in Table 12. The composition of target data frames in engineering mode is shown in Table 13, and some data is added to the data reported in normal working mode.

Table11 Target basic information and data composition

Target state	Movement target distance (cm)	Motion of the target energy values	Statics target distance (cm)	Statics target energy value	Detect range(cm)
1byte (table12)	2bytes	1byte	2bytes	1byte	2bytes

Table12 Description of the target status value

Target status value	Description
0x00	No target
0x01	Motion target
0x02	Stationary state
0x03	Movement & stationary targets

Table13 Target data (project mode) frame composition

...	Detection distance (cm)	Maximum movement	Maximum stationary distance	Movement distance gate 0	...	Movement distance	Stationary distance	...	Stationary-distance	Keep the data
-----	-------------------------	------------------	-----------------------------	--------------------------	-----	-------------------	---------------------	-----	---------------------	---------------

		ent distance gate N	gate N	energy value		gate N energy value	gate 0 energy value		gate N energy value	and store the additional information
...	2 bytes	1byte	1byte	1byte	...	1byte	1byte	...	1byte	M byte

Report data example:

Report the data in the normal working mode:

Frame header	Intra-frame data length	Intra-frame data	End of frame
F4 F3 F2 F1	0D 00	02 AA 02 51 00 00 00 00 3B 00 00 55 00	F8 F7 F6 F5

Report the data in the engineering mode:

Frame header	Intra-frame data length	Intra-frame data	End of frame
F4 F3 F2 F1	0D 00	01 AA 03 1E 00 3C 00 00 39 00 00 08 09 3C 22 05 03 03 04 03 06 05 00 00 39 10 13 06 06 08 04 03 05 55 00	F8 F7 F6 F5

2.4. Radar command configuration mode

2.4.1. Radar command configuration step

The process of Rd-01 radar executing a configuration command includes "send command" and "reply command ACK" of the radar. If the radar fails without ACK reply or ACK reply, the radar fails to execute the configuration command.

As mentioned earlier, before sending any other command to the radar, the developer needs to send the "enabling Configuration" command and then send the configuration command within the specified time. After the command configuration is complete, the End Configuration command is sent to inform that the radar configuration has ended.

For example, to read the radar configuration parameters, the upper computer first sends the

"enable configuration" command; sends the "read parameters" command after receiving the radar ACK is successful; finally sends the "end configuration" command; after the radar ACK is successful, the complete action of the read parameter is over. The radar command configuration process is shown in the following figure.

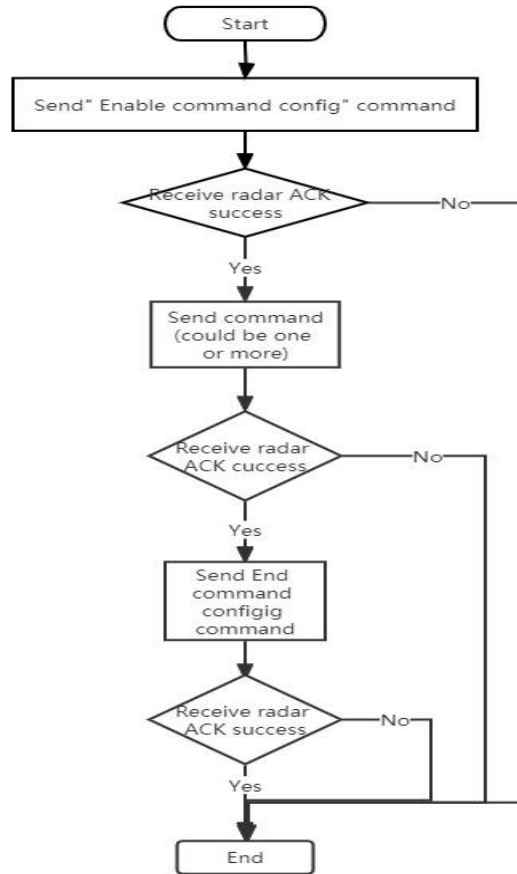

Figure 2 Flow chart of radar command configuration

2.4.2. Attentions for radar configuration

Timeout mechanism: Send the enable configuration command before command processing on the radar. After the EnConfiguration command, the 3-second command configuration phase enters where multiple commands can be configured. In the timing stage, the radar has no other data output except for the command response. If the radar receives no command within 3 seconds, it will automatically exit the command

3. Contact us

[Ai-Thinker official website](#)

[Office forum](#)

[Develop DOCS](#)

[LinkedIn](#)

[Tmall shop](#)

[Taobao shop](#)

[Alibaba shop](#)

[Technical support email: support@aithinker.com](mailto:support@aithinker.com)

[Domestic business cooperation: sales@aithinker.com](mailto:sales@aithinker.com)

[Overseas business cooperation: overseas@aithinker.com](mailto:overseas@aithinker.com)

Company Address: Room 403,408-410, Block C, Huafeng Smart Innovation Port, Gushu 2nd Road, Xixiang, Baoan District, Shenzhen.

Tel: +86-0755-29162996



WeChat mini program



WeChat official account

Disclaimer and copyright notice

The information in this article, including the URL address for reference, is subject to change without notice.

The document is provided "as is" without any guarantee responsibility, including any guarantee for merchantability, suitability for a specific purpose, or non-infringement, and any guarantee mentioned elsewhere in any proposal, specification or sample. This document does not bear any responsibility, including the responsibility for infringement of any patent rights arising from the use of the information in this document. This document does not grant any license for the use of intellectual property rights in estoppel or other ways, whether express or implied.

The test data obtained in the article are all obtained from Ai-Thinker's laboratory tests, and the actual results may vary slightly.

All brand names, trademarks and registered trademarks mentioned in this article are the property of their respective owners, and it is hereby declared.

The final interpretation right belongs to Shenzhen Ai-Thinker Technology Co., Ltd.

Notice

Due to product version upgrades or other reasons, the contents of this manual may be changed.

Shenzhen Ai-Thinker Technology Co., Ltd. reserves the right to modify the contents of this manual without any notice or prompt.

This manual is only used as a guide. Shenzhen Ai-Thinker Technology Co., Ltd. makes every effort to provide accurate information in this manual. However, Shenzhen Ai-Thinker Technology Co., Ltd. does not guarantee that the contents of the manual are completely free of errors. All statements and information in this manual and the suggestion does not constitute any express or implied guarantee.

Important statement

Ai-Thinker may provide technical and reliability data "as is" (including data sheets), design resources (including design for reference), application or other design recommendations, network tools, security information and other resources (the "these resources") and without warranty without express or implied warranty, including without limitation adaptability, suitability for a particular purpose or infringement of intellectual property rights of any third party. And specifically declares that it is not liable for any inevitable or incidental loss arising from the application or the use of any of our products and circuits.

Ai-Thinker reserves the right to the information released in this document (including but not limited to the indicators and product description) and any changes to the Company without notice to automatically replace and replace all the information provided in the previous version of the same document number document.

These resources are available to skilled developers who design Ai-Thinker products. You will bear all the responsibilities for the following: (1) select the appropriate optional products for your application; (2) design, verify, and run your application and products during the full life cycle; and (3) ensure that your application meets all corresponding standards, norms and laws, and any other functional security, information security, regulatory or other requirements.

Ai-Thinker authorizes you to use these resources only for the application of the Essence products described in this resource. Without the permission of Ai-Thinker, no unit or individual shall copy or copy part or all of these resources without authorization, and shall not spread them in any form. You are not entitled to use any other Principal or any third party intellectual property. You shall fully indemnify for any claims, damages, costs, losses and debts incurred by the result of the use of these resources.

The products available by Ai-Thinker are subject to the terms of sales or other applicable terms attached to the products. Ai-Thinker may provide these resources does not extend or otherwise change the applicable warranty or warranty disclaimer for the product release.