



Ra-08-P Specification

Version V1.0.0

Copyright ©2024

Document resume

Version	Date	Develop/revise content	Edition	Approve
V1.0.0	2024.11.12	First Edition	PengfeiDong	NingGuan

Content

1. Product overview	4
1.1. Characteristic	6
2. Main parameters	7
2.1. Static electricity requirement	7
2.2. Electrical characteristics	8
2.3. Digital port characteristics	8
2.4. RF parameters	9
3. Appearance Dimensions	10
4. Pin Definition	11
5. Schematic	13
6. Design Guidance	14
6.1. Application circuit	14
6.2. Recommend PCB footprint size	15
6.3. Antenna installation	15
6.4. Power supply	16
6.5. GPIO level conversion.	17
6.6. Software writing	17
7. Frequently Asked Questions	18
7.1. Factors affecting transmission distance	18
7.2. Modules usage precautions	18
7.3. Factors causing interference with the module	19
8. Storage condition	20
9. Reflow welding curve diagram	20
10. Product packaging information	21
11. Contact us	21
Disclaimer and copyright notice	22
Notice	22

1. Product overview

Ra-08-P is a high-power LoRa module designed and developed by Shenzhen Anxinke Technology Co., Ltd., which is used for ultra-long-distance spread spectrum communication. Its chip ASR6601 is a general-purpose LPWAN wireless communication SoC that integrates an RF transceiver, a modem, and a 32-bit RISC MCU. The MCU uses an ARM core and has an operating frequency of up to 48MHz. The Ra-08-P module supports LoRa modulation and traditional (G)FSK modulation under LPWAN use cases; at the same time, the transmitter also supports BPSK modulation and (G)MSK modulation, and the receiver supports (G)MSK modulation. Based on this technology, the module has built-in power amplifiers (PA) and low-noise amplifiers (LNA), with high sensitivity exceeding -137dBm, +29dBm transmission power, long transmission distance, and high reliability. At the same time, compared with traditional modulation technologies, LoRa™ modulation technology also has obvious advantages in anti-blocking and selection, solving the problem that traditional design solutions cannot take into account distance, anti-interference and power consumption at the same time.

The Ra-08-P module provides ultra-long range and ultra-low power communication for LPWAN applications and can be widely used in scenarios such as smart meters, supply chain and logistics, home building automation, security systems, remote irrigation systems, etc.

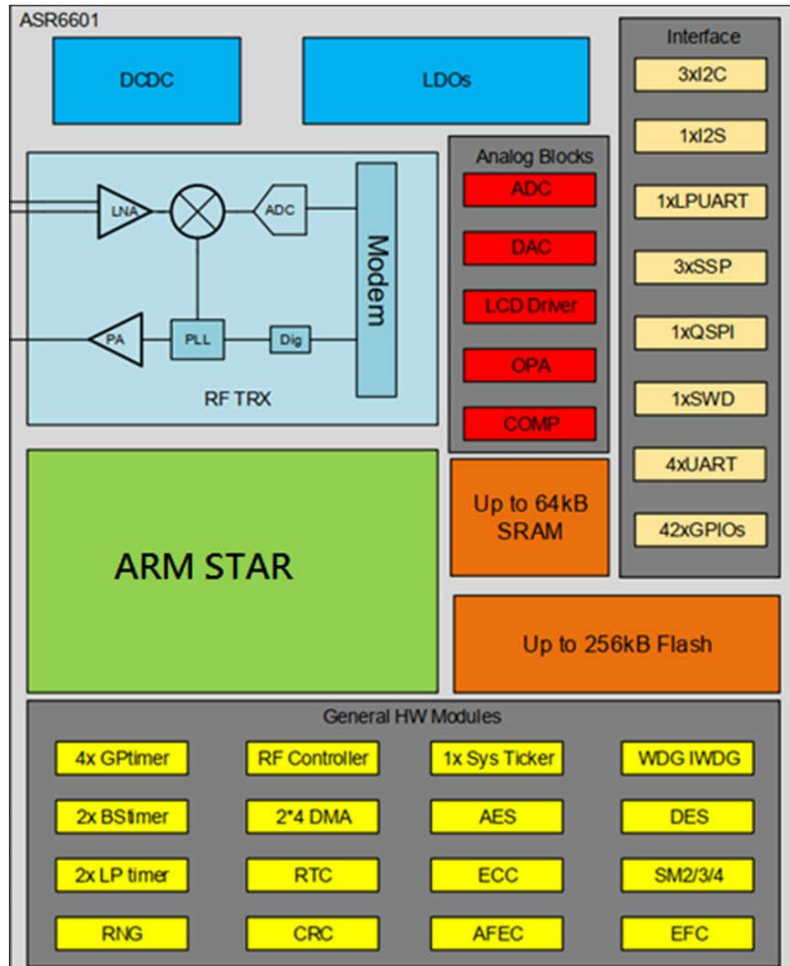

Figure 1 Main chip block diagram

1.1. Characteristic

- SMD-18 package
- Supported frequency bands: 410MHz-525MHz
- The operating voltage is 3.3V, Theoretical maximum transmit power +29dBm
- High sensitivity: -137dBm @125Kz SF10
- Supported spreading factors SF5/SF6/SF7/SF8/SF9/SF10/SF11/SF12
- Embedded memory, 128KB FLASH, 16KB SRAM
- Support LoRa/(G)FSK/BPSK/(G)MSK modulation
- The antenna interface is compatible with various connection methods such as stamp hole/round hole and IPEX, supporting more solution selection.
- Support multiple sleep modes: deep sleep current as low as 17uA

2. Main parameters

Table1 Description of main parameters

Module	Ra-08-P
Package	SMD-18
Size	16.0*16.0*3.2(±0.2)mm
Antenna	Compatible with Half Hole Pad / Through Hole Pad / IPEX Sockets
Frequency range	410-525MHz
Operating temperature	-40 °C ~ 85 °C
Storage environment	-40 °C ~ 125 °C, < 90%RH
Power supply range	Supply voltage 2.8V ~ 3.6V, supply current >800mA
Support interface	UART/GPIO/ADC/DAC/I2C/I2S/SPI/PWM
Number of IO ports	IO2,IO4,IO5,IO8,IO9,IO11,IO14,IO15
Serial port rate	Support 110 ~ 4608000 bps, default 115200 bps
Crystal frequency	32MHz
SPI Flash	128KB
Transport protocol	LoRaWAN, LinkWAN

2.1. Static electricity requirement

Ra-08-P is electrostatic sensitive equipment, so special precautions should be taken during handling.



Figure 2 ESD anti-static diagram

Tip:

Ra-08-P modules are Electrostatic Sensitive Devices (ESD) and require special ESD precautions and should normally be applied to ESD sensitive components. Proper ESD handling and packaging procedures must be employed throughout the handling, shipping and operation of any application incorporating Ra-08-P modules. Do not damage the module by touching it with your hands or by soldering with a non-antistatic soldering iron.

2.2. Electrical characteristics

Table 2 Table of Electrical Characteristics

Parameter	Name		Min. value	Typical value	Max. value	Un	Note
Operating Temperature	TOPR		-40	25	85	°C	
Supply voltage	VDD		2.8	3.3	3.6	V	≥3.3V Guaranteed
Power consumption	Sleep Mode	Consumption 1	-	17	-	uA	DeepSleep
		Consumption 2	-	7	-	mA	standby mode
	Full-load mode (TX:29dBm)		-	700	-	mA	DC-DC Mode
	Reception mode (RX:SF7)		-	16	-	mA	DC-DC Mode

2.3. Digital port characteristics

Table 3 Digital Ports

Interface	Name	Min. value	Typical value	Max. value	Unit
IO Level	VIO	2.8	3.3	3.6	V
Input logic level low	VIL	-	-	0.2	V
Input logic level high	VIH	0.8	-	-	V
Output logic level low	VOL	-	-	0.1	V
Output logic level high	VOH	0.9	-	-	V

2.4. RF parameters

Table 4 RF parameters

Output power					
Mode	RF Band	Min.	Typical	Max.	Unit
Transmit power	433MHz	-	+29	-	dBm
Transmit power	470MHz	-	+29	-	dBm
Transmit power	490MHz	-	+29	-	dBm
Transmit power	510MHz	-	+29	-	dBm
Receiving sensitivity Modulation bandwidth 125kHz					
Mode		Min.	Typical	Max.	Unit
SF7		-	-127	-	dBm
SF8		-	-130	-	dBm
SF9		-	-134	-	dBm
SF10		-	-137	-	dBm

3. Appearance Dimensions



Front

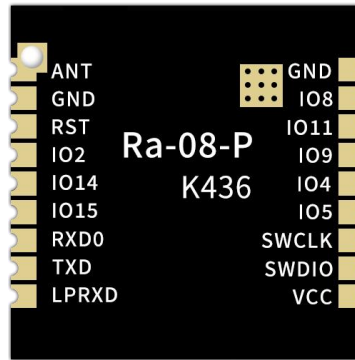

Back

Figure 3 Exterior view (Rendering for reference only, subject to physical condition)

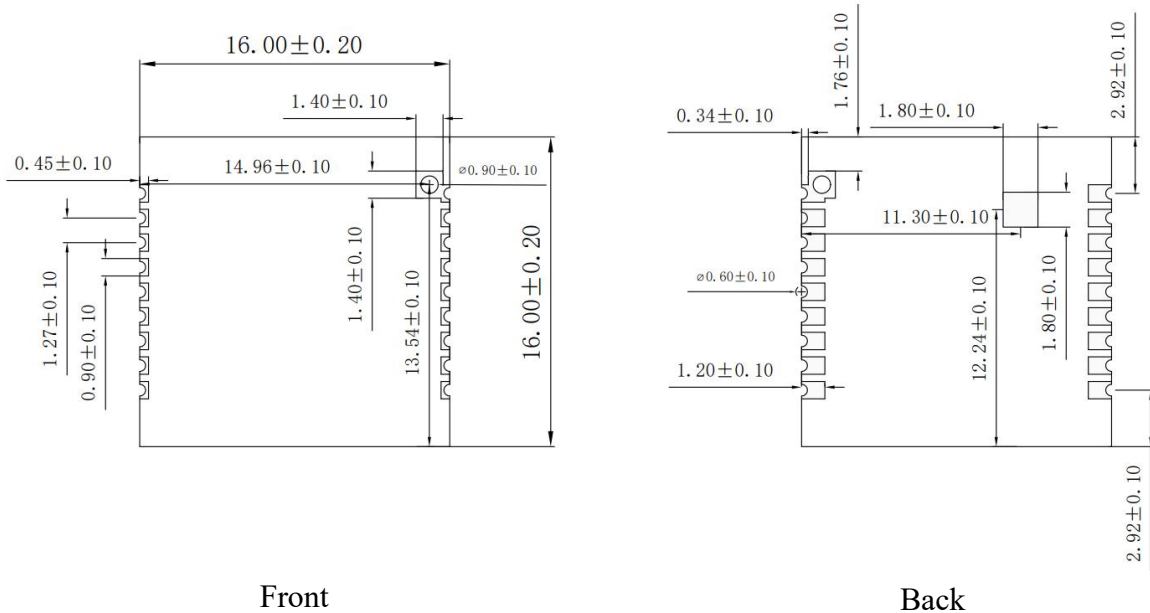

Front

Back

Figure 4 Dimensional drawing (unit: mm)

4. Pin Definition

Ra-08-P module connects 19 pins as shown in the pin diagram, and the pin function definition table is the interface definition.

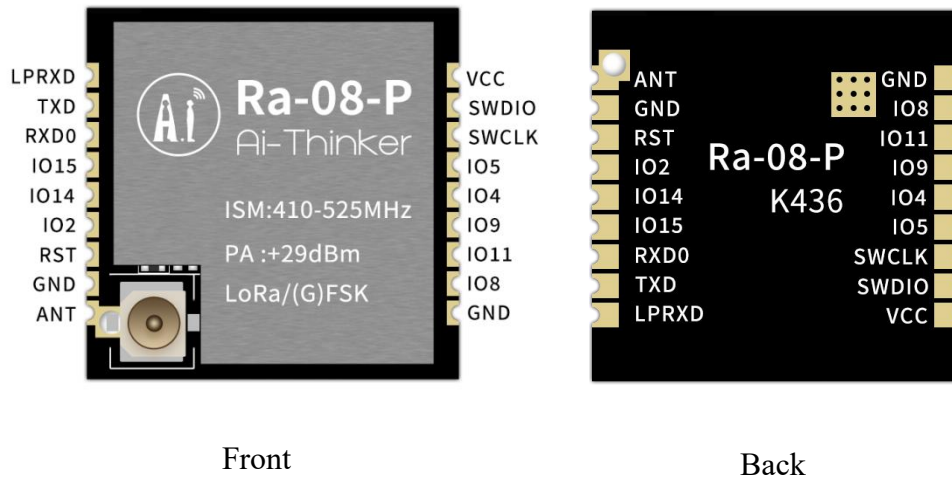

Figure 5 Pin diagram

Table 5 Definition table of pin functions

No.	Name	Function
1, 17	GND	Ground
2	IO8	GPIO8/ADC_IN1
3	IO11	GPIO11/ADC_IN0
4	IO9	GPIO9/DAC_OUT
5	IO4	GPIO4/SSP1_CLK
6	IO5	GPIO5/SSP1_NSS
7	SWCLK	GPIO7/SWD_CLK
8	SWDIO	GPIO6/SWD_DATA
9	VCC	3.3V supply, recommended supply current >800mA.
10	LPRXD	GPIO60/LPUART-RX, Communication serial port.
11	TXD	GPIO17/UART TX
12	RXD0	GPIO16/UART RX, Burning a serial port.
13	IO15	GPIO15/I2C_SDA
14	IO14	GPIO14/I2C_SCL
15	IO2	GPIO2/BOOT
16	RST	RSTN_IN External reset, active low.
18	ANT	Antenna Interface
EPAD	GND	Grounding, need to be reliable grounding, conducive to heat dissipation.

Table 6 Module start-up mode description.

System boot mode			
Pin	Default	SPI boot mode	Download boot mode
IO2	下拉	0	1

Note: Some pins have been internally pulled-up, refer to the schematic.

5. Schematic

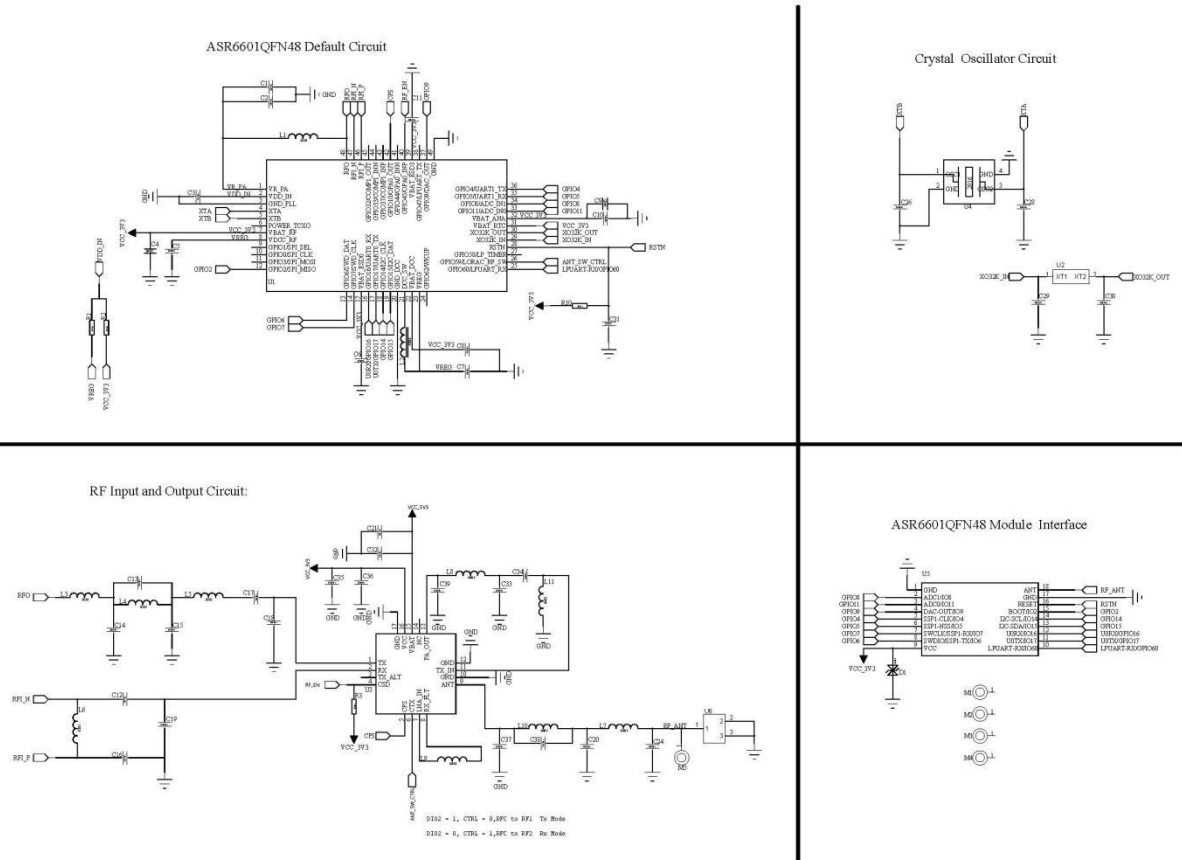
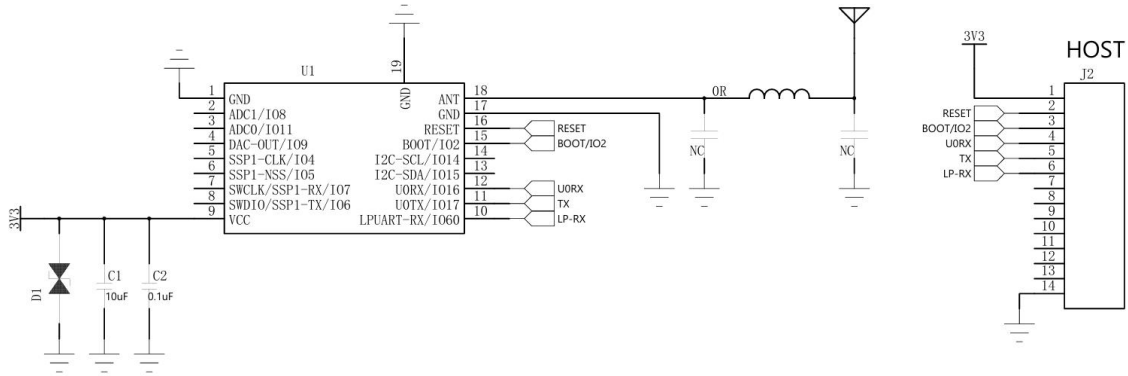

Figure 6 Schematic

6. Design Guidance

6.1. Application circuit



(Recommended to use DC-DC or LDO independent power supply use,
the current is more than 800mA)

Figure 7 Application Circuit Diagram

Attention:

- IO2 is the boot control pin, low in normal operation mode, high in burn firmware mode. The chip is internally low by default.
- U0RX is the burning serial port and LPRXD is the communication serial port, please choose by yourself according to your requirement.
- The module cannot transmit unloaded, the ANT pin must be connected to a load/antenna to transmit, otherwise it will result in burning the FEM chip.
- The output power of the module ASR6601 chip should be strictly controlled within 5dBm, and the input power is too large which will lead to burn the FEM chip.

6.2. Recommend PCB footprint size

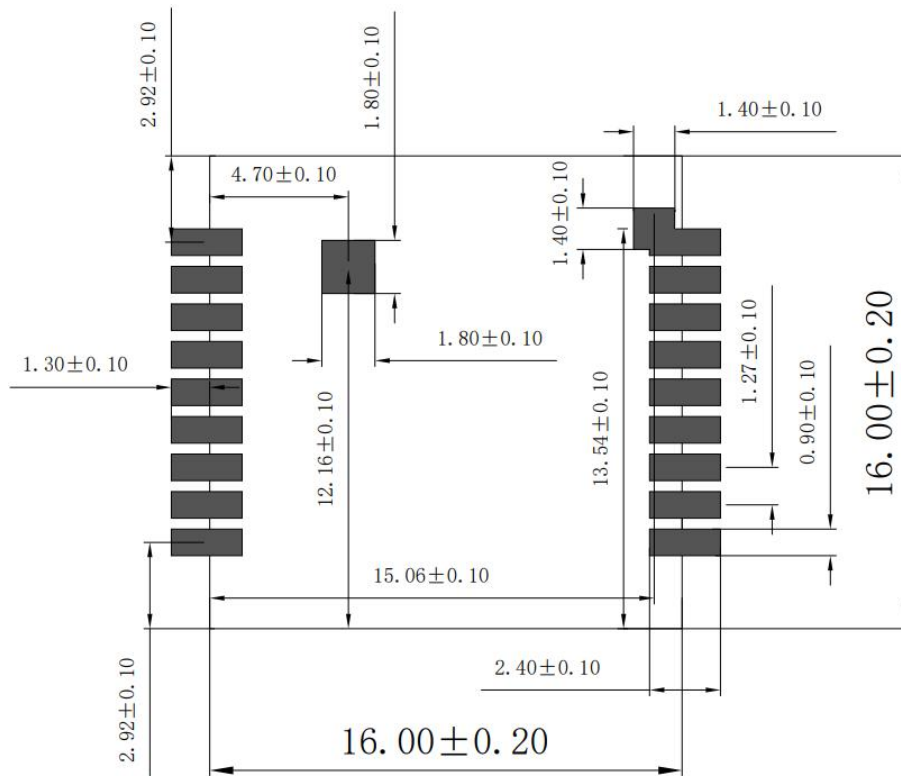

Figure 8 Recommended PCB package size diagram (unit: mm)

6.3. Antenna installation

- The Ra-08-P requires an external antenna for use, and the module has half-hole pads to lead to the motherboard.
- For optimal antenna performance, the antenna should be mounted away from metal parts.
- Antenna mounting structure has a great influence on the module performance, make sure the antenna is exposed, preferably vertically upwards. When the module is installed inside the case, you can use a good quality antenna extension cable to extend the antenna to the outside of the case.
- The antenna should never be mounted inside a metal case, as this will result in a significant weakening of the transmission range.

6.4. Power supply

- Recommends 3.3V voltage and 1A+ peak current.
- Recommends the use of LDO power supply; if using DC-DC it is recommended that the ripple is controlled within 100mV.
- The DC-DC power supply circuit recommends reserving the location of a dynamic response capacitor, which can optimise the output ripple when the load varies greatly.
- Additional ESD devices are recommended for the 3.3V power interface.
- When designing the power supply circuit for the module, it is recommended to keep more than 30% of the power supply current, so that the whole machine is conducive to long-term stable operation.
- Please pay attention to the correct connection of the positive and negative terminals of the power supply, such as reverse connection may lead to permanent damage to the module.

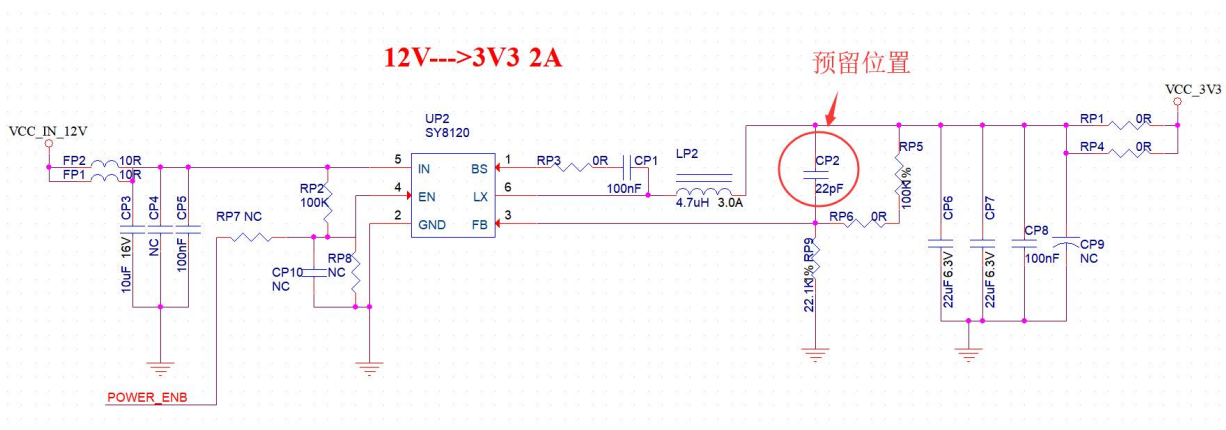

Figure 9 DC-DC Buck Circuit

6.5. GPIO level conversion.

- There are some IO ports leading out of the periphery of the module, if you need to use it, it is recommended to connect 10-100 ohm resistors in series on the IO ports. This will suppress overshoot and make the levels smoother on both sides. It is helpful for both EMI and ESD.
- The pull-up and pull-down of the special IO ports should be referred to the usage instructions in the datasheet, and the start-up configuration of the module will be affected here.
- The IO port of the module is 3.3V, if the IO port level of the master control and the module do not match, you need to add a level conversion circuit.
- If the IO port is directly connected to a peripheral interface, or a terminal such as a row of pins, it is recommended to reserve an ESD device in the IO port alignment near the terminal.

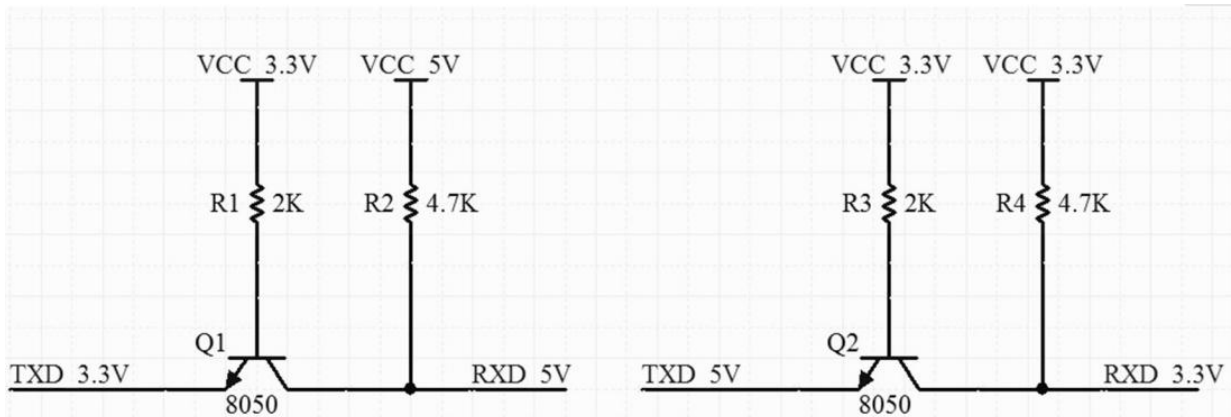

Figure 10 Level conversion circuit

6.6. Software writing

- The maximum input power of FEM chip can not exceed +5dBm, in order to avoid burning the FEM chip, users need to strictly configure the output power of ASR6601, recommended 3dBm.
- This module is an ASR6601+ peripheral circuit and the user can follow the ASR6601 chip manual exactly.

7. Frequently Asked Questions

7.1. Factors affecting transmission distance

- When there is a straight-line communication barrier, the communication distance is attenuated accordingly.
- Temperature, humidity, and co-frequency interference, can lead to increased communication packet loss.
- The ground absorbs and reflects radio waves and is less effective when tested close to the ground.
- Seawater has a very strong ability to absorb radio waves, so the results of the seaside test are poor.
- Signal attenuation can be very severe when there are metal objects near the antenna, or when it is placed in a metal case.
- The power register is set incorrectly, the air rate is set too high (the higher the air rate, the closer the distance).
- The low voltage of the power supply at room temperature is lower than the recommended value, and the lower the voltage, the lower the generating power.
- Using an antenna that is poorly matched to the module or the quality of the antenna itself.

7.2. Modules usage precautions

- Check the power supply to ensure that it is between the recommended supply voltages, exceeding the maximum value can cause permanent damage to the module.
- Check the stability of the power supply, the voltage should not fluctuate significantly and frequently.
- Ensure that the process of installation and use of anti-static operation, high-frequency devices electrostatic sensitivity.
- Ensure that the process of installation and use should not be too high humidity, some components are humidity sensitive devices.
- It is not recommended to use it at too high or too low a temperature if there is no special need.

7.3. Factors causing interference with the module

- There is co-channel signal interference in the vicinity, stay away from the interference source or modify the frequency or channel to avoid the interference.
- The clock waveform on SPI is not standard, check whether there is interference on the SPI line, and the SPI bus alignment should not be too long.
- Unsatisfactory power supply may also cause garbled code, be sure to ensure the reliability of the power supply.
- Poor quality or too long extension cables and feeder cables can also cause high BER.

8. Storage condition

Products sealed in moisture-proof bags should be stored in a non-condensing atmosphere of <math> < 40^{\circ} \text{C} / 90\% \text{RH}</math>.

The moisture sensitivity class MSL of the module is 3.

After the vacuum bag is unpacked, it must be used within 168 hours at $25 \pm 5^{\circ} \text{C} / 60\% \text{RH}</math>, otherwise it will need to be baked before it can be put on line a second time.$

9. Reflow welding curve diagram

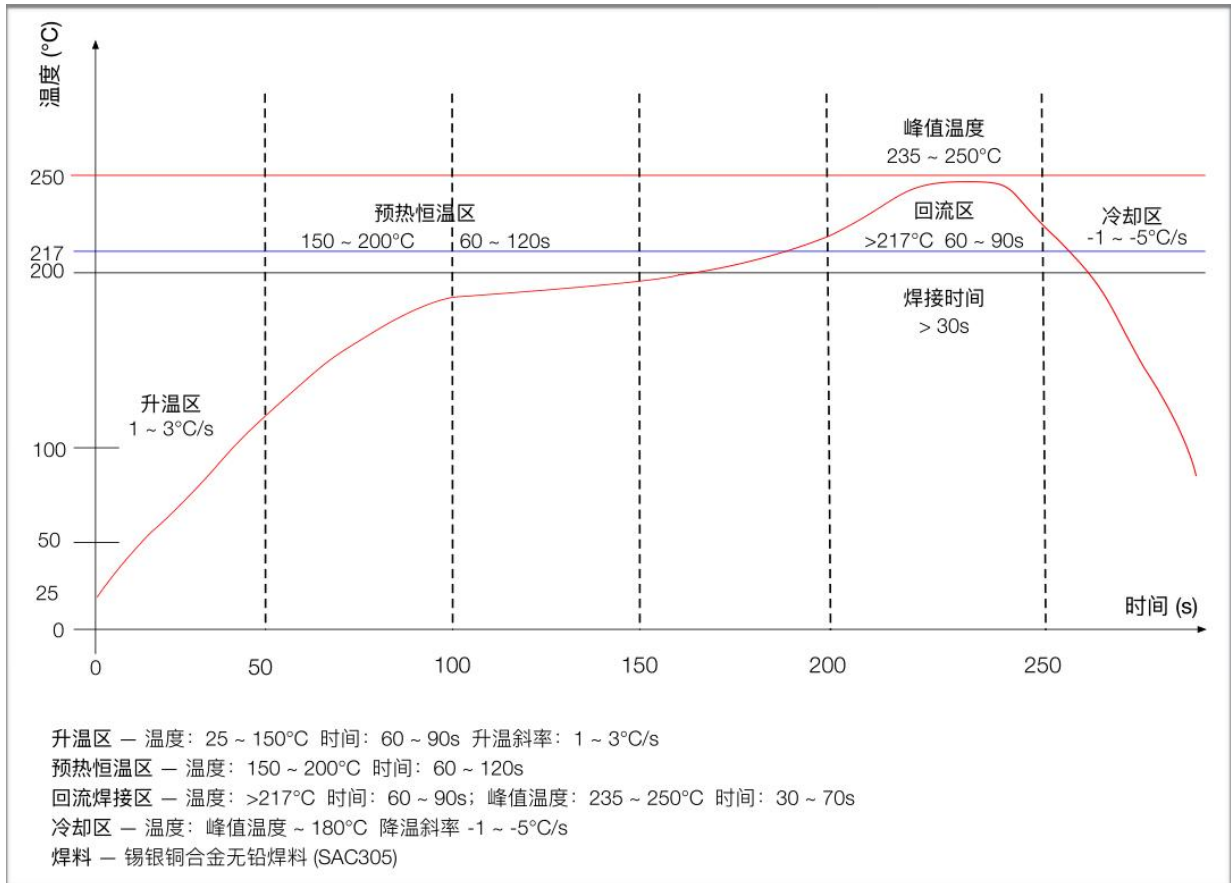

Figure 11 Reflow welding curve

10. Product packaging information

Ra-08-p is packaged in braided tape, 750pcs/tray. As shown in the picture below:



Figure 12 Packing braid

11. Contact us

[Ai-Thinker official Website](#)

[Official Fourm](#)

[Develop DOCS](#)

[Linkedin](#)

[Tmall shop](#)

[Taobao shop](#)

[Alibaba shop](#)

[Technial suppot Email: support@aithinker.com](mailto:support@aithinker.com)

[Domestic business cooperation: sales@aithinker.com](mailto:sales@aithinker.com)

[Overseas business cooperation: overseas@aithinker.com](mailto:overseas@aithinker.com)

Company address: Room 403,408-410, Block C, Huafeng Smart Innovation Port, Gushu 2nd Road, Xixiang, Baoan District, Shenzhen.

Tel: 0755-29162996



WeChat mini



WeChat official

Disclaimer and copyright notice

The information in this article, including the URL address for reference, is subject to change without notice. The document is provided "as is" without any guarantee responsibility, including any guarantee for merchantability, suitability for a specific purpose, or non-infringement, and any guarantee mentioned elsewhere in any proposal, specification or sample. This document does not bear any responsibility, including the responsibility for infringement of any patent rights arising from the use of the information in this document. This document does not grant any license for the use of intellectual property rights in estoppel or other ways, whether express or implied. The test data obtained in the article are all obtained from Ai-Thinker's laboratory tests, and the actual results may vary slightly. All brand names, trademarks and registered trademarks mentioned in this article are the property of their respective owners, and it is hereby declared. The final interpretation right belongs to Shenzhen Ai-Thinker Technology Co., Ltd.

Notice

Due to product version upgrades or other reasons, the contents of this manual may be changed. Shenzhen Ai-Thinker Technology Co., Ltd. reserves the right to modify the contents of this manual without any notice or prompt. This manual is only used as a guide. Shenzhen Ai-Thinker Technology Co., Ltd. makes every effort to provide accurate information in this manual. However, Shenzhen Ai-Thinker

Technology Co., Ltd. does not guarantee that the contents of the manual are completely free of errors. All statements and information in this manual. And the suggestion does not constitute any express or implied guarantee.