



BW20-07S Specification

Version V1.0.0

Copyright ©2024

Content

1. Product overview	4
1.1. Characteristic	5
2. Main parameters	6
2.1. Static electricity requirement	6
2.2. Electrical characteristics	7
2.3. Wi-Fi RF performance	7
2.4. BLE RF performance	9
2.5. Power consumption	10
3. Appearance size	11
4. Pin definition	14
5. Schematic diagram	16
6. Design guide	18
6.1. Circuit guidance of application	18
6.2. Recommend PCB package size	18
6.3. Antenna layout requirements	19
6.4. Power supply	19
6.5. GPIO	19
7. Storage conditions	20
8. Reflow welding curve diagram	20
9. Product packaging information	21
10. Contact us	21
Disclaimer and copyright notice	22
Notice	22
Important statement	23

1. Product overview

BW20-07S is a dual-band Wi-Fi + BLE SoC module developed by Ai-Thinker based on RTL8711 series chips, which supports dual-band (2.4 GHz or 5 GHz) 802.11a/b/g/n WLAN protocol and Bluetooth 5.0 protocol. The BW20-07S integrates dual-core MCU, an ARM V8.1 (Cortex-M4F compatible) high-performance MCU with a maximum frequency of 330 MHz; an ARM V8M (Cortex-M0 compatible) low-power MCU.

The BW20-07S module has rich peripheral interfaces, including UART / GPIO / ADC / PWM / IIC / SPI / SDIO / IR / SWD / USB etc. It can be widely used in the Internet of Things (IoT), mobile devices, wearable electronic devices, smart home and other fields.

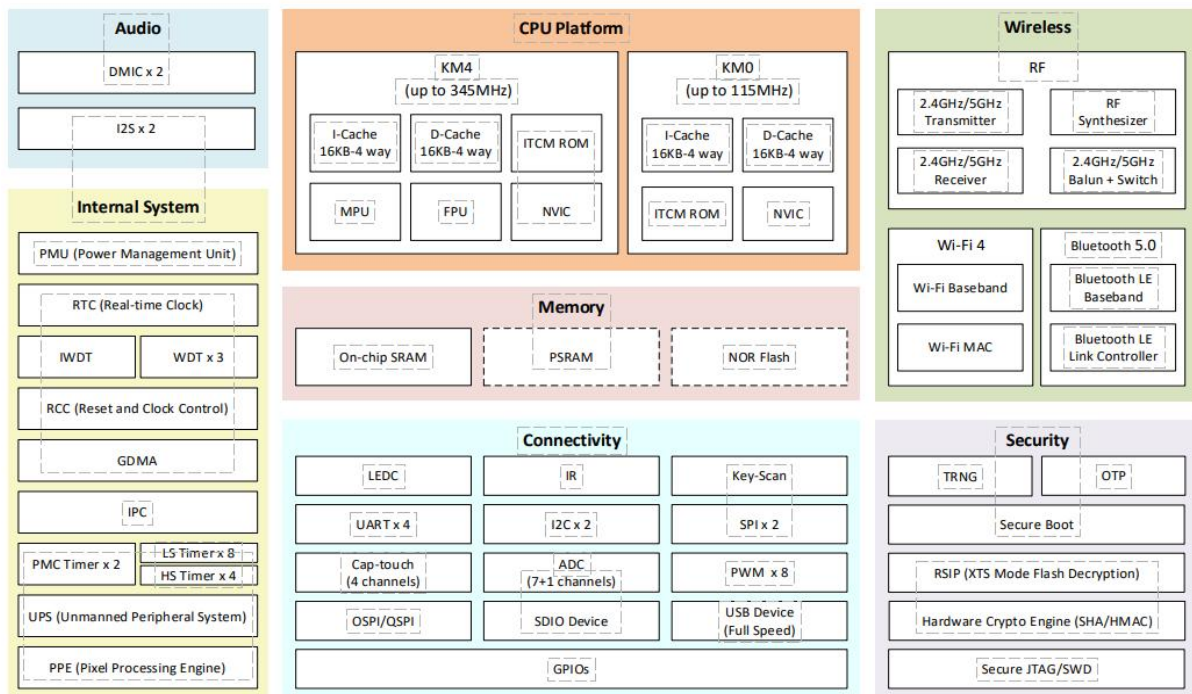

Figure 1 Chip Block Diagram

1.1. Characteristic

- Support for the 802.11a/b/g/n protocol
- Support for dual-frequency 2.4GHz or 5GHz
- Supports the HT 20 / HT 40 mode
- Support for Bluetooth 5.0
- Support for BLE Long Range
- The Bluetooth supports a high-power mode LE data length extension
- Support for link layer privacy
- Support for the hardware encryption engine
- Integrated dual-core MCU, up to 330 MHz
- Abundant interfaces, with 17 flexible IO ports
- Wi-Fi and Bluetooth share the same antenna
- Support secondary development, support programming in Linux and Windows environments
- Support for Arduino development

2. Main parameters

Table 1: Description of the main parameters

Model	BW20-07S
Package	SMD-23
Size	17*16*3.2(±0.2)MM
Antenna	IPEX connector (4th generation)
Frequency range	2400~2483.5MHz or 5180~5825MHz
Operating temperature	-40 °C~85 °C
Storage temperature	-40 °C~125 °C,<90%RH
Power supply	Voltage supply 3.0V~3.6V,typical value 3.3V, Current supply>500mA
Support interface	UART/GPIO/ADC/PWM/IIC/SPI/SDIO/IR/SWD/USB
Available IO	Default 17
UART rate	Default 115200bps
Bluetooth	BLE 5.0
SPI flash	Default 4MByte, Max support 16MByte

2.1. Static electricity requirement

The BW20-07S module is an electrostatically sensitive device and requires special ESD precautions. Usually, ESD protection devices should be added during use. The correct ESD handling and packaging methods must be used during the transportation, operation and use of the BW20-07S module. Do not touch the module with your hands or use a non-antistatic soldering iron for soldering to avoid damaging the module.



Figure 2 ESD Anti-static diagram

2.2. Electrical characteristics

Table 2 Electrical characteristics table

Parameters	Condition	Min.	Typical value	Max.	Unit
Voltage supply	3V3	3.0	3.3	3.6	V
I/O	VIL	-	-	0.3*VDD	V
	VIH	-	0.65*VDD	-	V
	VOL	-	-	0.15*VDD	V
	VOH	-	-	0.85*VDD	V

2.3. Wi-Fi RF performance

Table 3 Wi-Fi RF performance

Description	Typical			Unit
Frequency range	2400~2483.5 and 5180~5825			MHz
Output power				
Mode	Min. value	Typical	Max. value	Unit
11a mode, PA output power	-	18	-	dBm
11b mode, PA output power	-	19	-	dBm
11g mode, PA output power	-	18	-	dBm
11n mode, PA output power	-	17	-	dBm
Receiving sensitivity				
Mode	Min.value	Typical	Max. value	Unit
11b, 1Mbps	-	-99	-	dBm
11b, 11Mbps	-	-90	-	dBm
11a/g, 6Mbps	-	-94	-	dBm
11a/g, 54Mbps	-	-76	-	dBm
HT20 (MCS0)	-	-93	-	dBm
HT20 (MCS7)	-	-74	-	dBm
HT40 (MCS0)	-	-91	-	dBm
HT40 (MCS7)	-	-71	-	dBm

2.4. BLE RF performance

Table 4 BLE RF performance

Description	Typical value			Unit
Frequency range	2400 ~ 2484MHz			MHz
Output power				
Rate mode	Min.value	Typical	Max.value	Unit
1Mbps	-	15	-	dBm
2Mbps	-	15	-	dBm
Receiving sensitivity				
Rate mode	Min.value	Typical	Max.value	Unit
1Mbps @30.8%PER	-	-98	-	dBm
2Mbps @30.8%PER	-	-97	-	dBm

2.5. Power consumption

The following power consumption data are based on the 3.3V power supply and the ambient temperature of 25° C.

- The POUT power for all transmission modes is measured at the antenna interface.
- All emission data were measured in the mode of continuous transmitting.

Table 5 Power consumption table

Mode	Min. value	Average value	Max. value	Unit
Tx 802.11b, 11Mbps, POUT=+22dBm	-	323	-	mA
Tx 802.11g, 54Mbps, POUT =+20dBm	-	98	-	mA
Tx 802.11n, MCS7, POUT =+20dBm	-	96	-	mA
Rx 802.11b	-	47	-	mA
Rx 802.11g	-	47	-	mA
Rx 802.11n	-	47	-	mA

3. Appearance size



Front

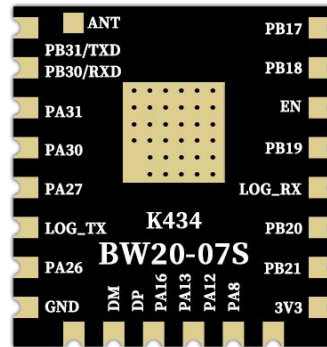

Back

Figure 3 Appearance diagram (rendering diagram is for reference only, subject to physical objects)

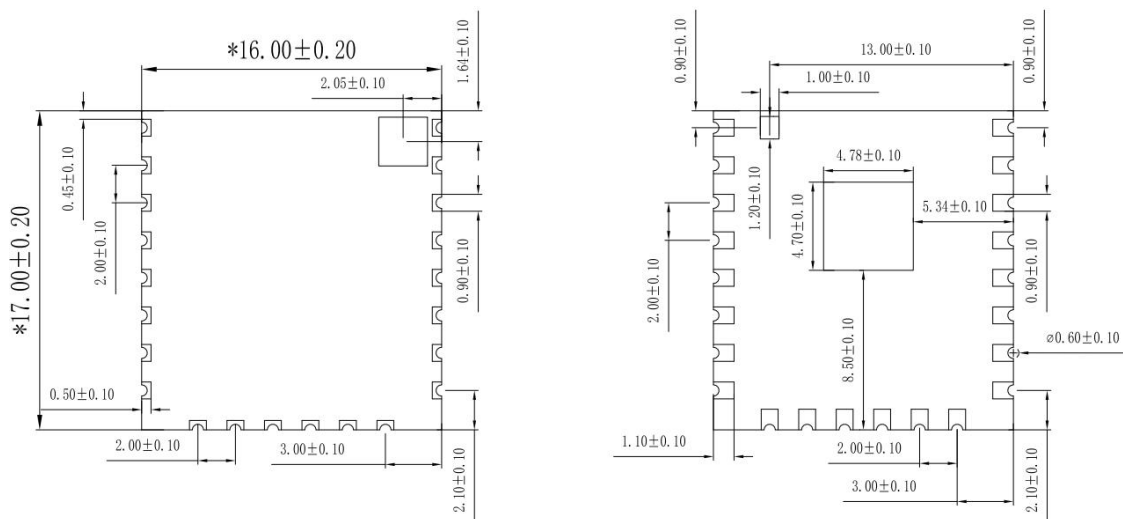

Front

Back

Figure 4 Size diagram

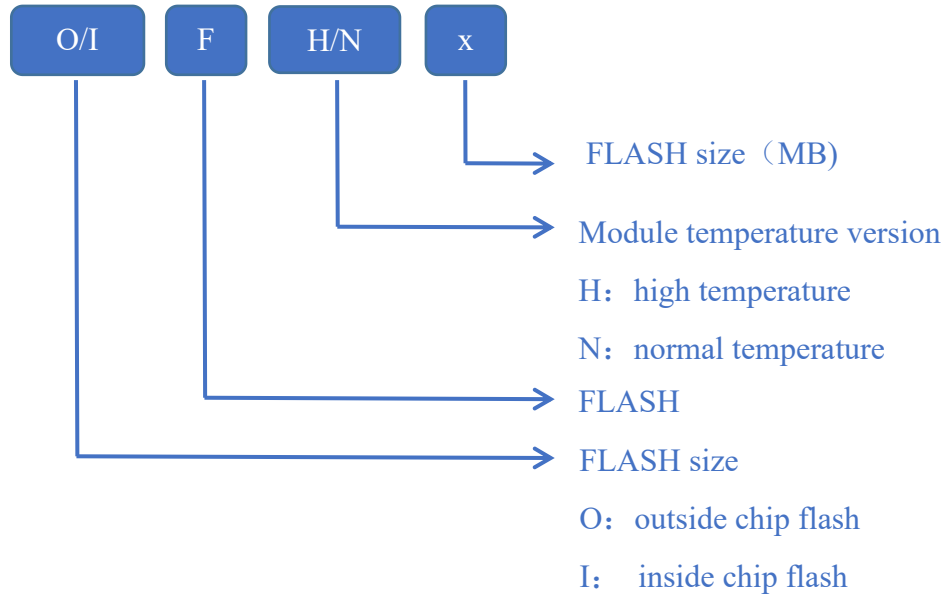

Figure 5 The screen cover information

4. Pin definition

BW20-07S is connected a total of 23 pins, as in the pin schematic diagram, and the definition of the pin function is shown in the following table.

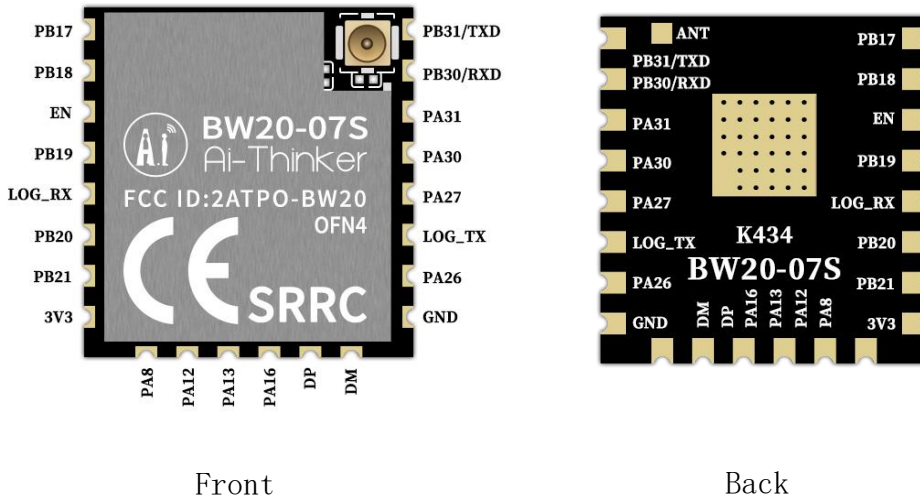

Figure 6 Pin diagram

Table 6 Pin function definition table

No	Name	Function description
1	PB17	TOUCH2_ADC2/SPI1_CS/SD_D3
2	PB18	TOUCH1_ADC1/SPI1_CLK/SD_CMD
3	EN	Chips enable pin and pull up effectively
4	PB19	TOUCH0_ADC0/SPI1_MOSI/SD_CLK
5	LOG_RX	UART_LOG_RXD, Firmware download RX pin
6	PB20	SPI1_MISO/SWD_CLK/SD_D0
7	PB21	SPI1_CS/SWD_DAT/SD_D1
8	3V3	3.3V power supply (VDD), the external power supply output current is recommended in above 500mA
9	PA8	PSRAM_DQ5/TIM8_TRIG
10	PA12	SPI0_CS/SD_D2/TIM9_TRIG
11	PA13	The default is not available and the IO is occupied by Flash inside the module. Please contact Ai-Thinker if need to use. SD_D2/external Flash this pin is NC

12	PA16	The default is not available and the IO is occupied by Flash inside the module. Please contact Ai-Thinker if need to use. SPI0_MISO/SD_CLK/external Flash this pin is NC
13	DP	PA29/SPI1_CLK/SD_CLK/FSDP
14	DM	PA28/SPI0_MISO/SD_CMD/FSDM
15	GND	Ground
16	PA26	SPI0_CLK/SD_D2
17	LOG_TX	UART_LOG_TXD, firmware download TX pin, Please do not external pull down, which will enter the Flash download mode.
18	PA27	SPI0_MOSI/SD_D3
19	PA30	SPI1_MOSI/SWD_CLK/SD_D0, default function is SWD DATA, IC can be configured as PA31
20	PA31	SPI1_MISO/SWD_DAT/SD_D1, default function is SWD DATA, IC can be configured as PA31
21	PB30/RXD	UART1_RXD, Do not external pull down, external pull down will enter Load OTP settings
22	PB31/TXD	UART1_TXD, Do not external pull down, external pull down will enter test mode
23	ANT	ANT pin. Hanging over when not in use, ANT pin do not cross the surface of the bottom plate.

Note: 1. When the LOG _ TX power is low, the module enters the burning mode; when the power is high, the module starts normally and the internal pull up by default.

2. PA13 and PA16 are internally occupied in the external Flash versions. At this time, the two IO are not available, and the pins are suspended.

3. PB 30 / RXD Do not pull down externally, external pull down will enter Load OTP settings.

4. PB 31 / TXD Do not pull down externally, the external pull down will enter the chip test mode.

5. The ANT pin is the antenna pin. When not in use, ANT pin do not cross the surface of the bottom plate.

5. Schematic diagram

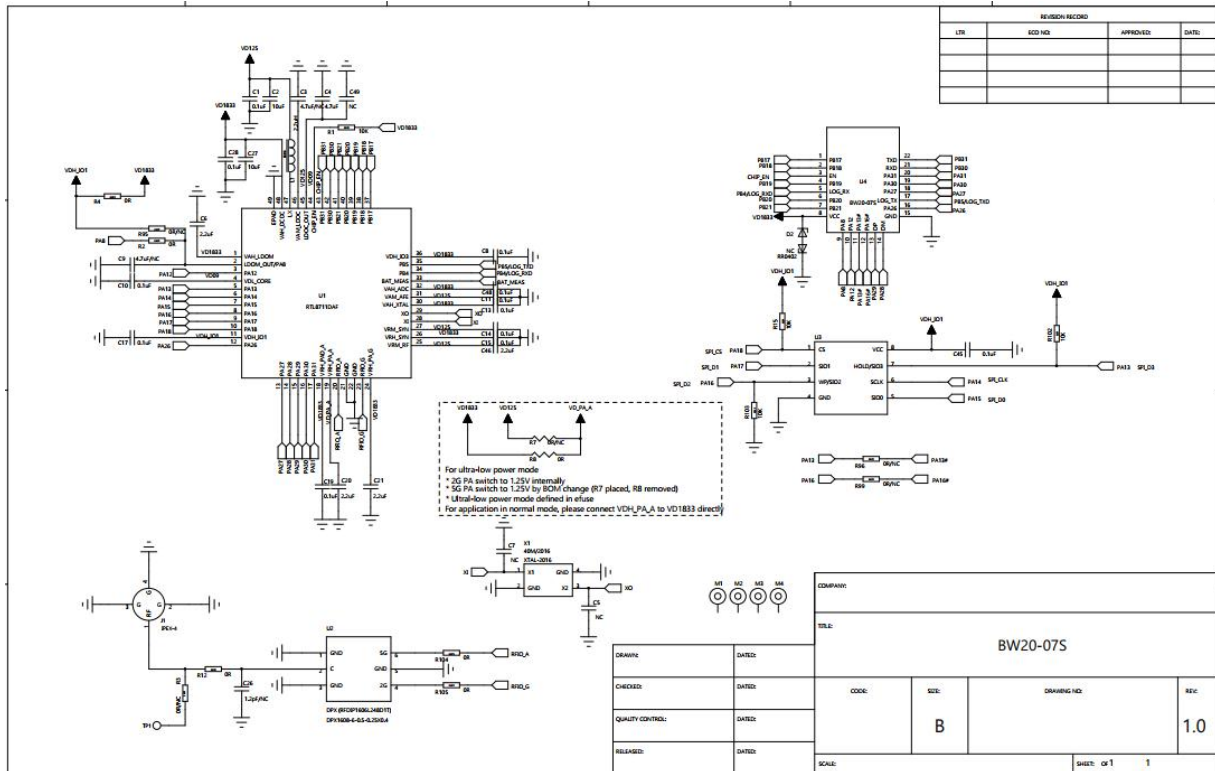

Figure 7 Schematic diagram

6. Design guide

6.1. Circuit guidance of application

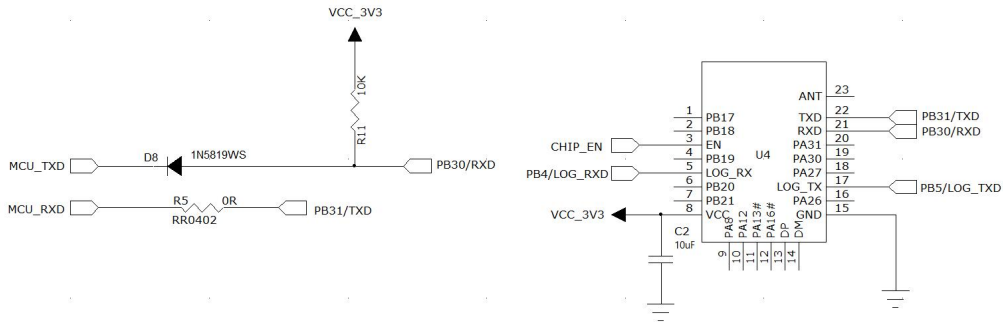

Figure 8 Application guidance circuit

Note:

- LOG_TX is the starting control pin in normal operating mode at high level and burning firmware mode at low level. Internal chip default high level.

6.2. Recommend PCB package size

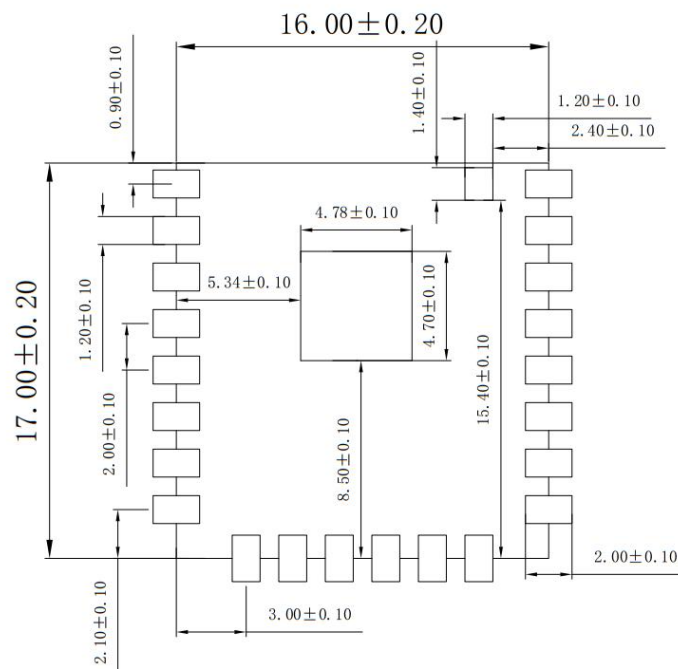

Figure9 Recommend PCB package size (TOP view)

Note: when ANT pin are not used, the module package is not reflected; for layout ANT pin do not cross the surface of the bottom plate.

6.3. Antenna layout requirements

- The module requires use by an external antenna.
- In order to satisfy the performance of the antenna, metal parts are prohibited around the antenna away from high frequency devices.

6.4. Power supply

- Recommended 3.3V voltage, peak current above 500 mA.
- It is recommended to use LDO; if DC-DC, ripple control within 30 mV.
- The DC-DC power supply circuit suggests to reserve the position of the dynamic response capacitor, which can optimize the output ripple when the load change is large.
- 3.3V power interface, it is recommended to add ESD devices.
- If the power supply is boosted from 1.5V to 3.0V for more than 15 ms, add the voltage reset IC or use the wide voltage version Flash.
- During the repeated up and down process, if the voltage cannot be less than 0.3V, the voltage reset IC must be increased.

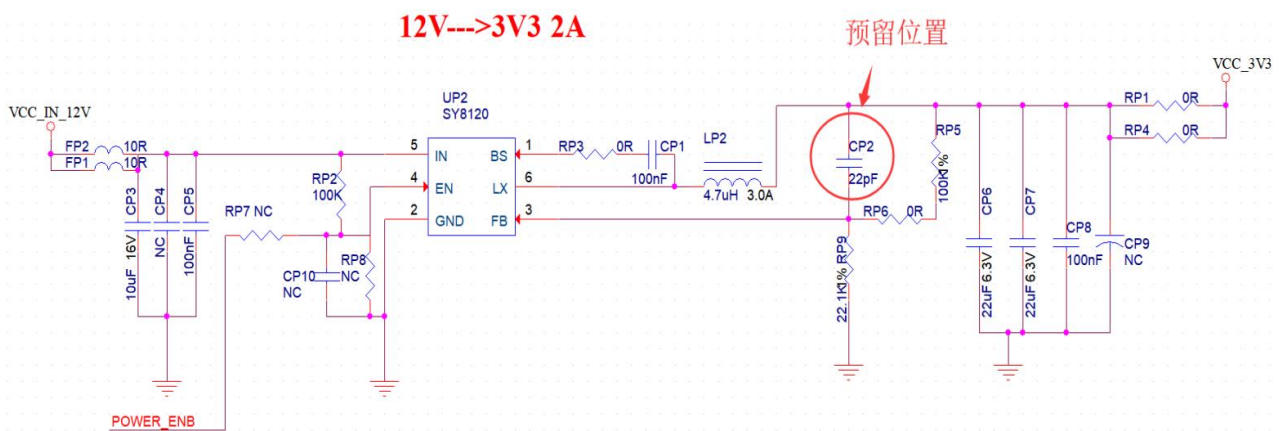

Figure 10 The DC-DC step-down circuit diagram

6.5. GPIO

- The periphery of the module introduces some IO ports and, if necessary, uses the recommended resistance of 10-100 ohms in series on the IO ports. This can suppress the overshoot and make the level on both sides more stable. For both EMI and ESD.
- Pull up and down of the special IO port, refer to the instructions of the specification, which will affect the startup configuration of the module.
- The IO port of the module is 3.3V. If the main control does not match the IO port level of

the module, the level conversion circuit should be added.

- If the IO port is directly connected to the peripheral interface or terminals, it is recommended to reserve ESD devices at the IO port line near the terminal.

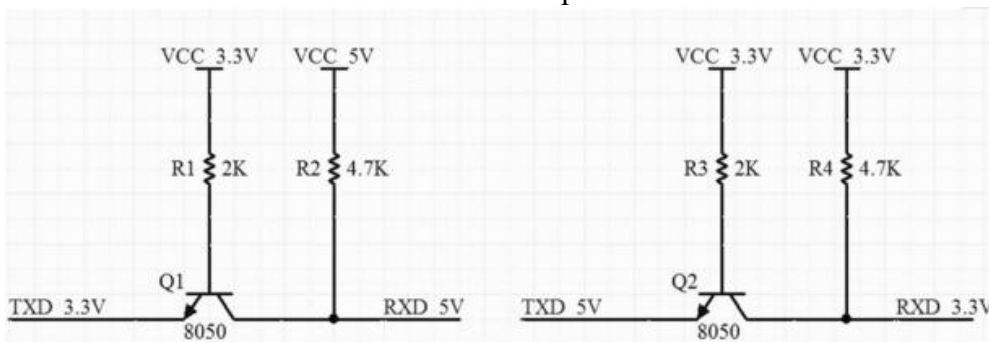

Figure 11 The level conversion circuit

7. Storage conditions

Products sealed in moisture-proof bags should be stored in a non-condensing atmosphere of $<40^{\circ}\text{C} / 90\%\text{RH}$.

The module has a moisture sensitivity rating of MSL 3.

After the vacuum bag is opened, it must be used within 168 hours at $25\pm 5^{\circ}\text{C} / 60\%\text{RH}$, otherwise it needs to be baked before it can be put on line again.

8. Reflow welding curve diagram

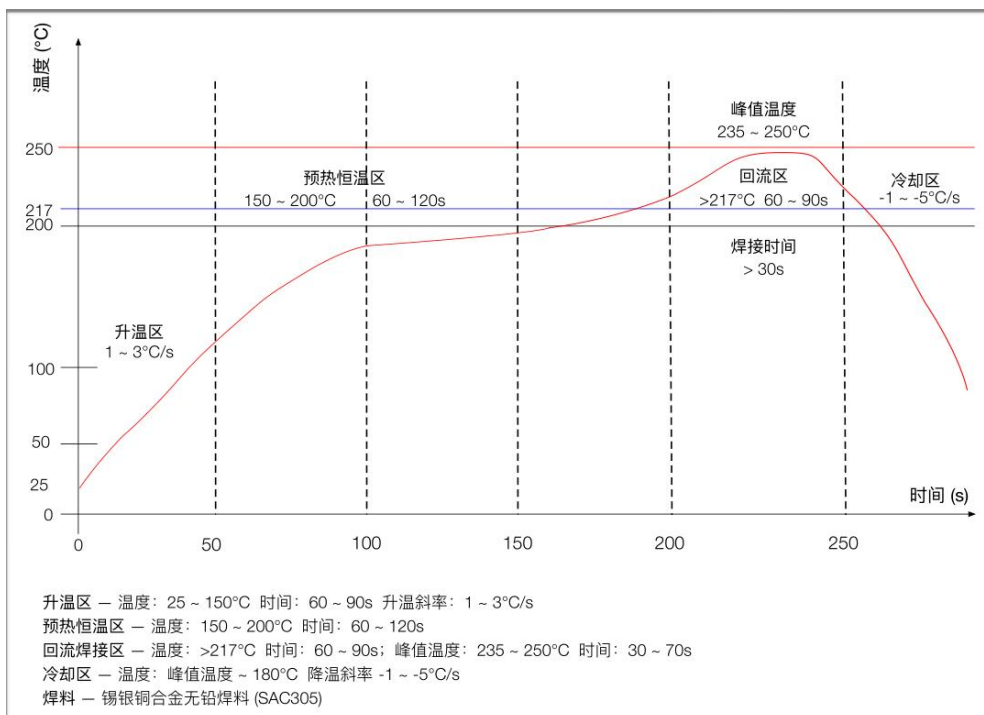

Figure 12 Reflow welding diagram

9. Product packaging information

BW20-07S module module was packaged in a tape, 800pcs/reel. As shown in the below image:



Figure 13 Package and packing diagram

10. Contact us

[Ai-Thinker official website](#)

[Office forum](#)

[Develop DOCS](#)

[LinkedIn](#)

[Tmall shop](#)

[Taobao shop](#)

[Alibaba shop](#)

Technical support email: support@aithinker.com

Domestic business cooperation: sales@aithinker.com

Overseas business cooperation: overseas@aithinker.com

Company Address: Room 403-405,408-410, Block C, Huafeng Smart Innovation Port, Gushu 2nd Road, Xixiang, Baoan District, Shenzhen.

Tel: +86-0755-29162996



WeChat mini program



WeChat official account

Disclaimer and copyright notice

The information in this article, including the URL address for reference, is subject to change without notice.

The document is provided "as is" without any guarantee responsibility, including any guarantee for merchantability, suitability for a specific purpose, or non-infringement, and any guarantee mentioned elsewhere in any proposal, specification or sample. This document does not bear any responsibility, including the responsibility for infringement of any patent rights arising from the use of the information in this document. This document does not grant any license for the use of intellectual property rights in estoppel or other ways, whether express or implied.

The test data obtained in the article are all obtained from Ai-Thinker's laboratory tests, and the actual results may vary slightly.

All brand names, trademarks and registered trademarks mentioned in this article are the property of their respective owners, and it is hereby declared.

The final interpretation right belongs to Shenzhen Ai-Thinker Technology Co., Ltd.

Notice

Due to product version upgrades or other reasons, the contents of this manual may be changed.

Shenzhen Ai-Thinker Technology Co., Ltd. reserves the right to modify the contents of this manual without any notice or prompt.

This manual is only used as a guide. Shenzhen Ai-Thinker Technology Co., Ltd. makes every effort to provide accurate information in this manual. However, Shenzhen Ai-Thinker Technology Co., Ltd. does not guarantee that the contents of the manual are completely free of errors. All statements and information in this manual And the suggestion does not constitute any express or implied guarantee.

Important statement

Ai-Thinker may provide technical and reliability data "as is" (including data sheets), design resources (including design for reference purposes), application or other design recommendations, network tools, security information and other resources (the "these resources") and without warranty without express or implied warranty, including without limitation, adaptability for a particular purpose or infringement of intellectual property rights of any third party. And specifically declares that it is not liable for any inevitable or incidental losses arising from the application or the use of any company products and circuits.

Ai-Thinker reserves the right to the information released in this document (including but not limited to the indicators and product description) and any changes to the Company without notice to automatically replace and replace all the information provided in the previous version of the same document number document.

These resources are available to skilled developers who design Ai-Thinker products. You will assume all responsibilities for the following: (1) select the appropriate optional products for your application; (2) design, verify, and run your application and products during the full life cycle; and (3) ensure that your application meets all corresponding standards, norms and laws, and any other functional security, information security, regulatory or other requirements.

Ai-Thinker authorizes you to use these resources only for the application of the Essence products described in this resource. Without the permission of Ai-Thinker, no unit or individual shall copy or copy part or all of these resources without authorization, and shall not spread them in any form. You are not entitled to use any other Principal or any third party intellectual property. You shall fully indemnify you for any claims, damages, costs, losses and debts incurred by the result of the use of these resources.

The products available by Ai-Thinker are subject to the terms of sales or other applicable terms attached to the products. Ai-Thinker may provide these resources does not extend or otherwise change the applicable warranty or warranty disclaimer for the product release.