

Project No: /
Date: 2018.05.15
Rev: 1.1

Product Specification

Customer name: _____

Model: _____ BG02 _____

B&T P/N: _____

Spec.: _____ GNSS SOC Module _____

Sealed by corporation:

Compilation	Verify	Approval
Guanning	Yangxiaofei	Sky-xu

Sealed by customer:

Check	Verify	Approval

Contact information of B&T:

ADD:10/F,Lingyun Administration Building,Liufang Road,The 67 District of Baoan District,Shenzhen		
Factory in Zhongshan: 3-4/F A Building,The Eastern Industrial Zone,Nam Long,Zhongshan		
TEL: 0760-88580932 FAX: 0760-89961414		
HTTP: http://www.tech-now.com		
sales:	MB:	E-mail:
support : yangxiaofei	MB:18802686018	E-mail: Yangxf@tech-now.com
Quality:	MB:	E-mail:

SPECIFICATION

BG02 Series Module





Change History of Revision

Revision	Date	Contents of Revision Change	Compilation	Verify
1.0	2018.04.10	Initial release	yangxiaofei	dengyuxing
1.1	2018.05.15	Increase series specifications	Guanning	Yangxiaofei

1. General Description

The BG02 is a highly integrated GNSS SOC module, Main chip is GK9501. It is a high-integration Multi-GNSS SOC that supports BDS/GPS/GLONASS/GALILEO/QZSS/SBAS with low power consumption. It integrates DC/DC, LDO, LNA, RF receiver, Base Band, 32-bit RISC CPU, RAM, Flash, RTC and PMU, and provides kinds of interfaces like UART, I2C, SPI and GPIO. The BG02 supports crystal and TCXO input. It also provides battery backed-up memory and a real-time clock to accelerate acquisition and reduce the TTFF (Time to First Fix).

2. Block Diagram

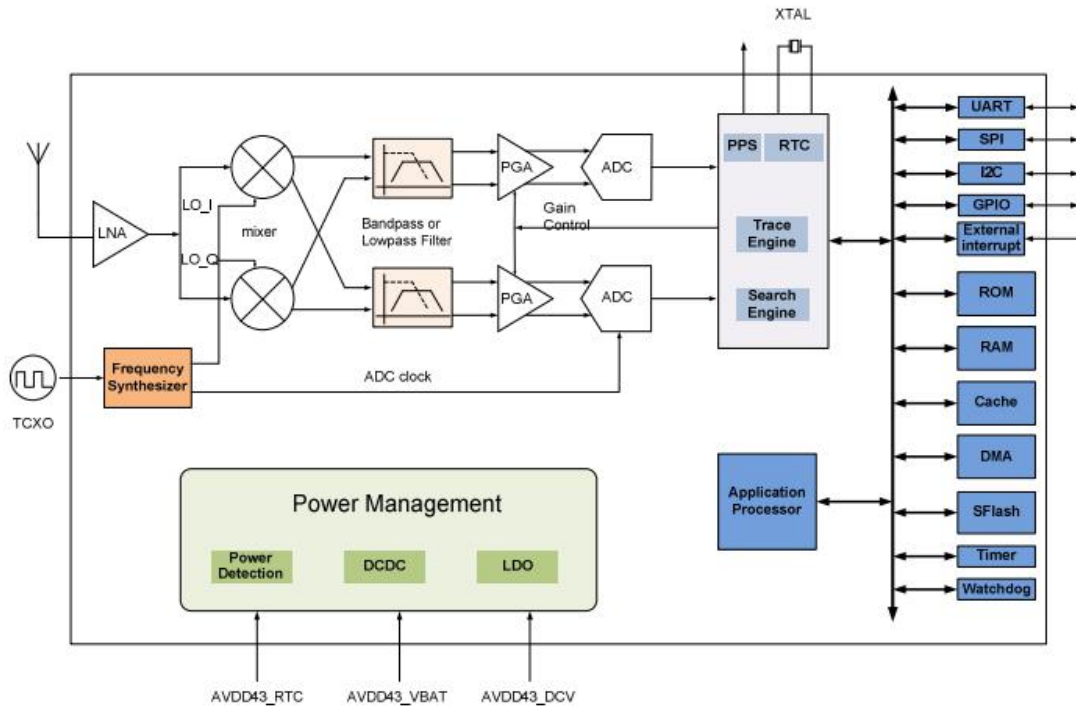

3. Functional description

Function	BG02 (G1H10S100)	BG02 (G2H10S100)	BG02 (GBH10S100)
GPS	YES	YES	YES
BDS	NO	NO	YES
GLONASS	NO	YES	NO
UART	YES	YES	YES
VCCRF	YES	YES	YES
PPS	YES	YES	YES
Antenna	External	External	External
Power Supply	Typ 3.3V	Typ 3.3V	Typ 3.3V
Size	10.3x9.9mm	10.3x9.9mm	10.3x9.9mm

4. Electrical Specifications

Category	Test Item	Typical	Unit
TTFF [Condition 1]	Cold Start	27.5	s
	Warm Start	<1	s
	Re-Acquisition	<1	s
	A-GNSS	<10	s
Sensitivity [Condition 2]	Cold Start	-148	dBm
	Warm Start	-162	dBm
	Re-Acquisition	-164	dBm
	Tracking	-166	dBm
Accuracy [Condition 3]	Horizontal position accuracy	2.5	m
	Altitude position accuracy	3.5	m
	Velocity accuracy	0.1	m/s
	Accuracy of Time pulse signal	30	ns
Power [Condition 4]	Acquisition Current@3.3v	30	mA
	Tracking Current@3.3v	20	mA
Operating Temperature		-40°C-85°C	°C

Storage Temperature		-65°C-150°C	°C
Humidity		5%-95%	

Note: Above test result based on GPS/BEIDO mode

[Condition 1]: The number of received satellite is more than six and signal of all those satellites is -130dBm. Test 10 times to take the average value and positioning accuracy is less than 10 meters

[Condition 2]: External LNA noise figure 0.8 and the number of received satellite is more than six. If in five minutes continuous lock the received signal strength is the test value

[Condition 3]: Wide and no blocking environment, continuous 24 hours test, 50%CEP

[Condition 4]: The number of received satellite is more than six and signal of all those satellites is -130dBm.

5. Package Dimensions & Pin definition

5.1 Package Dimensions

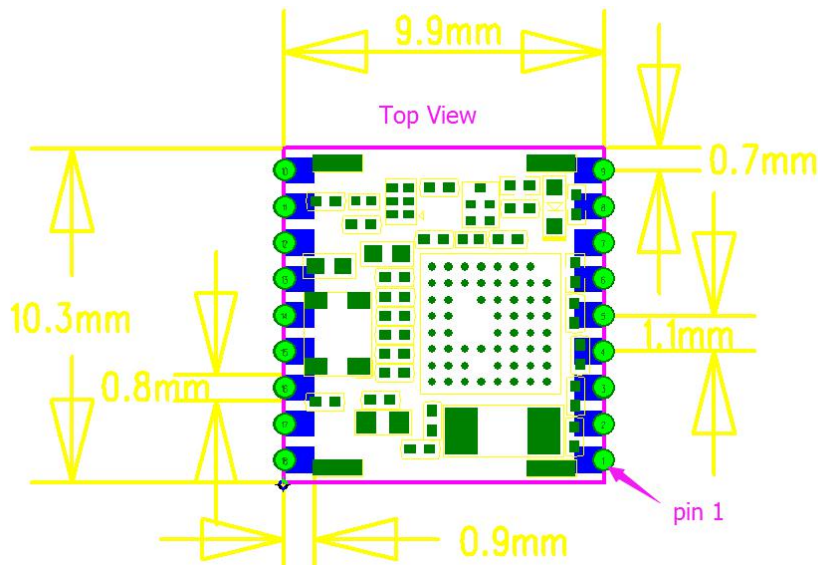

5.2 Pin Definition

Pin No.	Definition	Description	BG02 (G1H10S100)	BG02 (G2H10S100)	BG02 (GBH10S100)
1	GND	Ground	YES	YES	YES
2	TXD	UART output	YES	YES	YES
3	RXD	UART input	YES	YES	YES
4	PPS	Time pulse	YES	YES	YES

		signal			
5	NC	No connect	NC	NC	NC
6	VBKP	Backup power supply for internal RTC	YES	YES	YES
7	NC	No connect	NC	NC	NC
8	VCC	3.3V input	YES	YES	YES
9	NC	No connect	NC	NC	NC
10	GND	Ground	YES	YES	YES
11	RF_IN	GNSS signal input	YES	YES	YES
12	GND	Ground	YES	YES	YES
13	NC	No connect	NC	NC	NC
14	VCCRF	Output power for RF	YES	YES	YES
15	NC	No connect	NC	NC	NC
16	NC	No connect	NC	NC	NC
17	NC	No connect	NC	NC	NC
18	NC	No connect	NC	NC	NC