



Ai-WB3-01C Specification

Version V1.0.0

Copyright ©2023

Content

1. Product Overview	4
1.1. Characteristic	5
2. Main parameters	6
2.1. Static electricity requirement	6
2.2. Electrical characteristics	6
2.3. Wi-Fi RF Performance	7
2.4. BLE RF Performance	7
2.5. Power	8
3. Appearance Dimensions	9
4. Pin Definition	10
5. Schematic	12
6. Antenna parameters	13
6.1. Schematic diagram of the antenna test prototype	13
6.2. Antenna S parameter	14
6.3. Antenna Gain and Efficiency	14
6.4. Antenna pattern	15
7. Design Guidance	16
7.1. Application Guide Circuit	16
7.2. Recommend PCB footprint size	17
7.3. Antenna layout requirements	17
7.4. Power supply	18
7.5. GPIO	19
8. Storage conditions	20
9. Reflow welding curve diagram	20
10. Product Packaging Information	21
11. Contact us	21
Disclaimer and copyright notice	22
Notice	22

1. Product Overview

Ai-WB3-01C is a Wi-Fi&BLE module developed by Shenzhen Ai-Thinker Technology Co., Ltd. The module is equipped with LN882H chip as the core processor and supports Wi-Fi 802.11b/g/n protocol and BLE 5.1 protocol. The LN882H chip integrates the Cortex-M4F core, with a maximum frequency of 160MHz, built-in 296KB SRAM, 128KB ROM and rich peripheral interfaces, including SDIO/SPI/UART/I2C/PWM/ADC/DMA/SWD/GPIO, etc. It can be widely used in Internet of Things (IoT), mobile devices, wearable electronic devices, smart home and other fields.

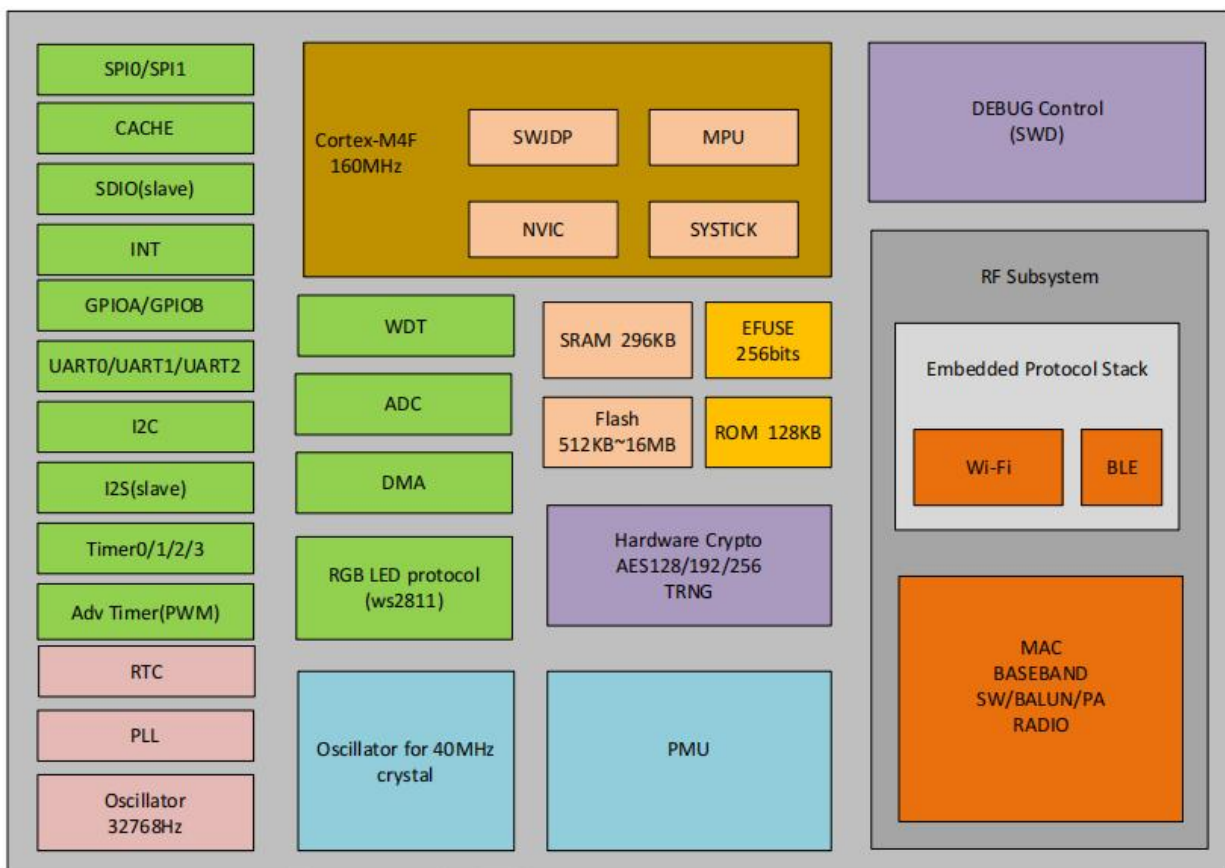

Figure 1 Main chip architecture diagram

1.1. Characteristic

- Package: SMD-21
- Support IEEE 802.11 b/g/n protocol
- Support BLE5.1
- Support long range (125Kbps, 500Kbps) and high data rate (2Mbps)
- Support 296KB SRAM / 128KB ROM
- Support SDIO/SPI/UART/I2C/PWM/ADC/DMA/SWD/GPIO port
- Support multi-channel ADC and programmable amplifier for sound sensors
- Support RTC real-time clock and WDT watchdog
- Supports True Random Number Generator (TRNG)
- Support AES-128\AES-192\AES-256 hardware encryption
- Support 256 bits EFUSE
- Integrated CHKSUM accelerator to improve TCP/UDP transmission

2. Main parameters

Table 1 Description of the main parameters

Model	Ai-WB3-01C
Package	SMD-21
Size	20.3*15.8*3.1(± 0.2)mm
Antenna	on-board PCB antenna
Frequency	2400 ~ 2483.5MHz
Operating temperature	-40°C ~ 85°C
Storage temperature	-40°C ~ 125°C, < 90%RH
Power supply	Support voltage 2.7V ~ 3.6V, supply current ≥ 500 mA
Interface	SDIO/SPI/UART/I2C/PWM/ADC/DMA/SWD/GPIO
IO	18
UART rate	Default 115200 bps
Security	AES-128\AES-192\AES-256 Hardware Encryption
Flash	Default 2MByte

2.1. Static electricity requirement

Ai-WB3-01C is an electrostatic sensitive device. Therefore, you need to take special precautions when carrying it.



Figure 2 ESD preventive measures

2.2. Electrical characteristics

Table 2 Electrical characteristics table

Parameters	Conditio	Min.	Typical value	Max.	Unit
Voltage Supply	VDD	2.7	3.3	3.6	V
I/O	VIL	-	-0.3	0.6	V
	VIH	-	VIO-0.6	VIO+0.3	V
	VOL	-	-0.45	0.45	v
	VOH	-	VIO-0.5	VIO+0.5	V

2.3. Wi-Fi RF Performance

Table 3 Wi-Fi RF performance table

Description	Typical value			Unit
Frequency range	2400 ~ 2483.5MHz			MHz
Output Power				
Mode	Min.	Typical value	Max.	Unit
11n Mode HT20, PA output power	-	14	-	dBm
11g Mode, PA output power	-	16	-	dBm
11b Mode, PA output power	-	18	-	dBm
Receive Sensitivity				
Mode	Min.	Typical	Max.	Unit
11b, 1 Mbps	-	-95	-	dBm
11b, 11 Mbps	-	-88	-	dBm
11g, 6 Mbps	-	-91	-	dBm
11g, 54 Mbps	-	-74	-	dBm
11n, HT20 (MCS7)	-	-71	-	dBm

2.4. BLE RF Performance

Table 4 BLE RF performance table

Description	Typical value			Unit
Frequency range	2400 ~ 2483.5MHz			MHz
Output Power				
Rate Mode	Min.	Typical value	Max.	Unit
1Mbps	-	10	-	dBm
Receive Sensitivity				
Rate Mode	Min.	Typical value	Max.	Unit
1Mbps sensitivity@30.8%PER	-	-94	-	dBm

2.5. Power

The following power consumption data is based on a 3.3V power supply and an ambient temperature of 25° C.

- All POUT power for all emission modes is measured at the antenna interface.
- All emission data is based on 95% of the duty ratio, measured in continuous emission mode.

Table 5 Power consumption

Mode		Min.	AVG	Max.	Unit
Tx 802.11b, 11Mbps, POUT=+18dBm		-	260	-	mA
Tx 802.11g, 54Mbps, POUT =+16dBm		-	247	-	mA
Tx 802.11n, MCS7, POUT =+14dBm		-	245	-	mA
Rx 802.11b, packet length 1024 byte		-	90	-	mA
Rx 802.11g, packet length 1024 byte		-	90	-	mA
Rx 802.11n, packet length 1024 byte		-	90	-	mA
Sleep Mode	DTIM=1	-	11	-	mA
	DTIM=3	-	8	-	mA

3. Appearance Dimensions

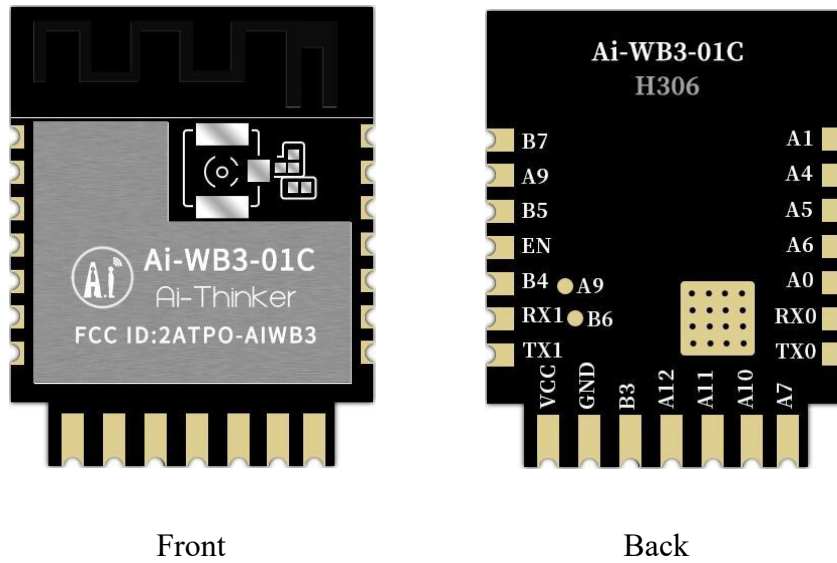

Figure 3 Appearance (the rendering is for reference only, the actual object shall prevail)

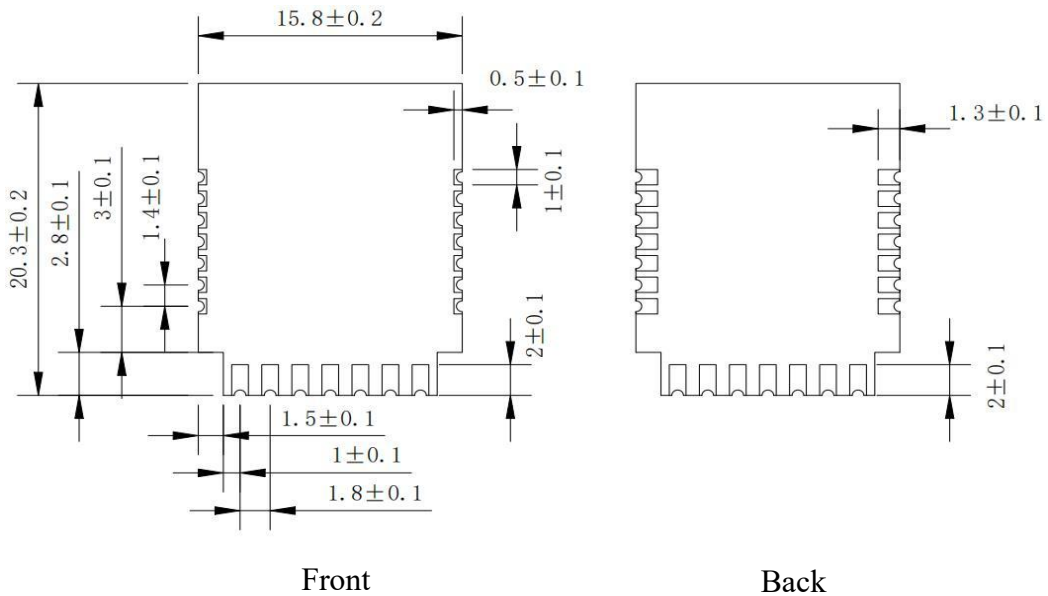

Figure 4 Dimension diagram (unit: mm)

4. Pin Definition

The Ai-WB3-01C module has a total of 21 pins connected, such as the pin schematic diagram, and the pin function definition table is the interface definition.

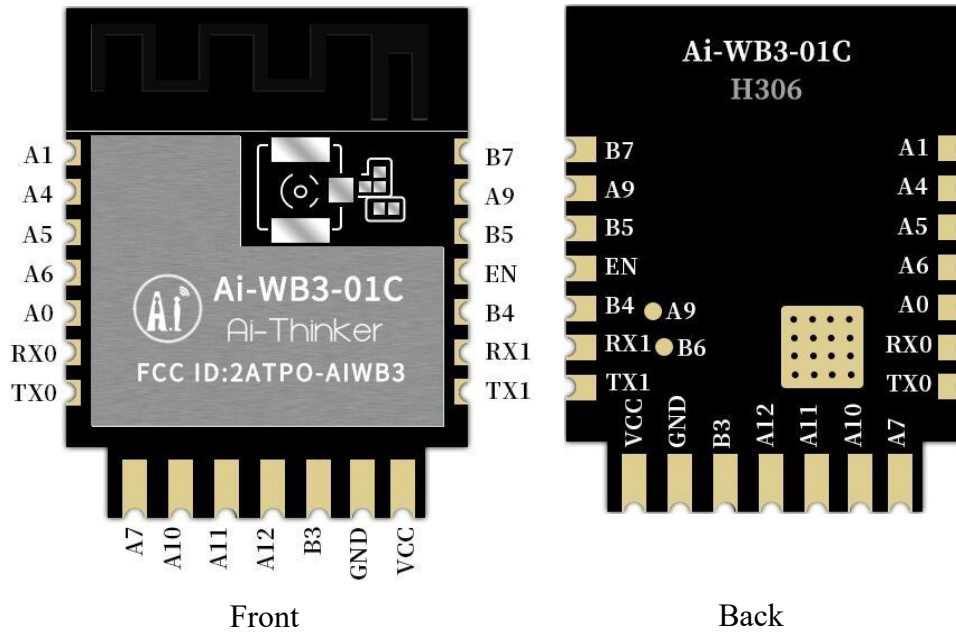

Figure 5 pin diagram

Table 6 Pin function definition table

No.	Name	Function Description
1	A1	GPIOA1/ADC/SWD/EXT_INT/FULLMUX
2	A4	GPIOA4/ADC/SWCK/FULLMUX
3	A5	GPIOA5/EXT_INT/FULLMUX
4	A6	GPIOA6/SDIO_IO2/I2S_SDI/EXT_INT/FULLMUX
5	A0	GPIOA0/ADC/EXT_INT/FULLMUX
6	RX0	RXD/GPIOA3/EXT_INT/FULLMUX
7	TX0	TXD/GPIOA2/EXT_INT/FULLMUX
8	A7	GPIOA7/SDIO_IO3/EXT_INT/FULLMUX
9	A10	GPIOA10/SDIO_IO0/I2S_SDO/FULLMUX
10	A11	GPIOA11/SDIO_IO1/FULLMUX
11	A12	GPIOA12/FULLMUX
12	B3	GPIOB3/ADC/FULLMUX
13	GND	Ground
14	VCC	3.3V power supply, the output current of the external power supply is recommended to be above 500mA
15	TX1	TXD/GPIOB9/FULLMUX/EXT_INT
16	RX1	RXD/GPIOB8/FULLMUX
17	B4	GPIOB4/ADC/FULLMUX
18	EN	Default as chip enable, active high
19	B5	GPIOB5/ADC/FULLMUX
20	A9	GPIOA9/SDIO_CLK/I2S_SCLK/FLLMUX/BOOT_MODE
21	B7	GPIOB7/FULLMUX
22	Measurement point 1	GPIOA9/SDIO_CLK/I2S_SCLK/FLLMUX/BOOT_MODE
23	Measurement point 2	GPIOB6/FULLMUX

Note: 1. IOA9 is used as Bootstrap. When the power is low at the moment of power-on, the module enters the programming mode; when the power is high at the moment of power-on, the module starts normally. The module supports 1 master/slave I2C interface and 2 SPI interfaces, and any two pins with FULLMUX characteristics can be configured as I2C and SPI.

5. Schematic

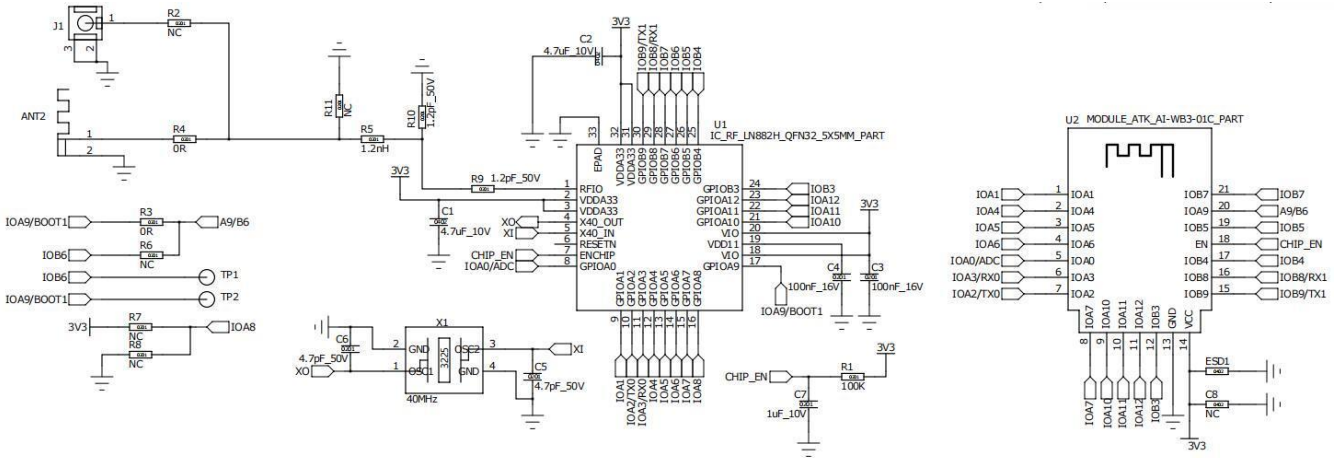

Figure 6 Module schematic

6. Antenna parameters

6.1. Schematic diagram of the antenna test prototype



Figure 7 Schematic diagram of the antenna test prototype

6.2. Antenna S parameter

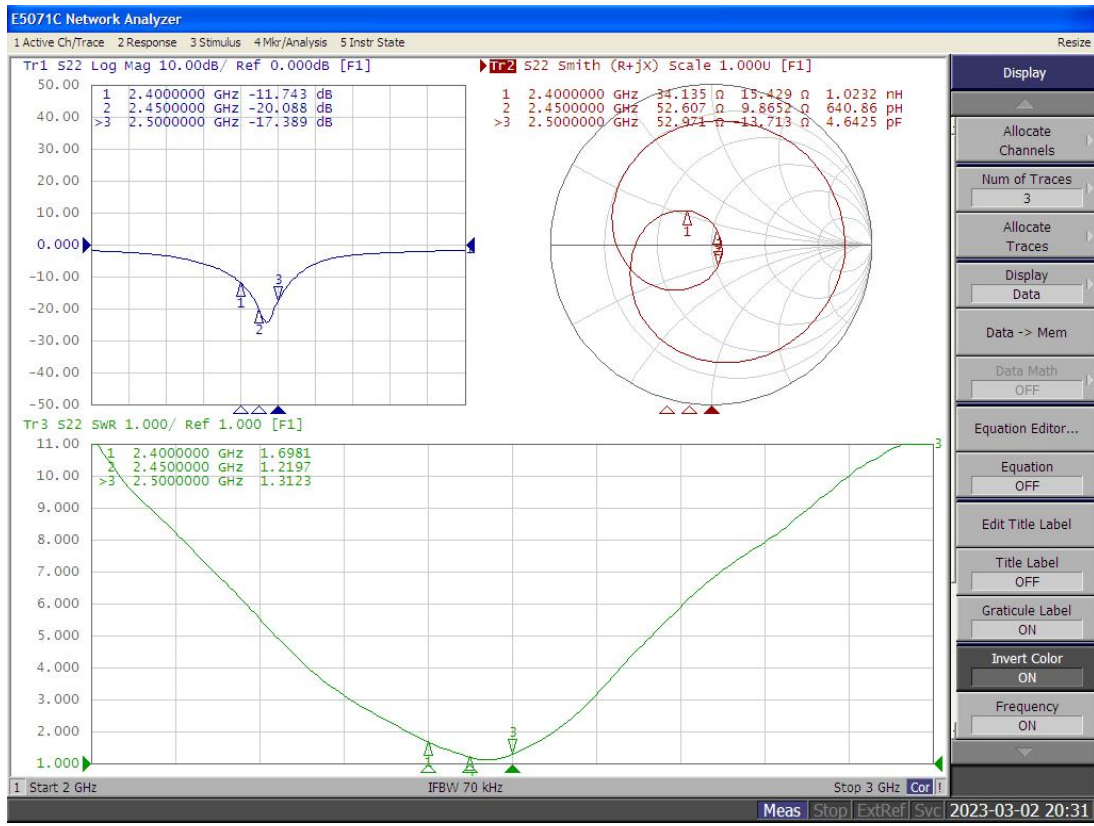

Figure 8 Antenna S parameters

6.3. Antenna Gain and Efficiency

Table 7 Antenna Gain and efficiency

Frequency ID	1	2	3	4	5	6	7	8	9	10	11
Frequency(MHz)	2400	2410	2420	2430	2440	2450	2460	2470	2480	2490	2500
Gain (dBi)	0.97	1.01	1.17	1.33	1.60	1.81	1.93	1.93	1.91	1.89	1.83
Efficiency (%)	49.1	48.8	49.4	50.7	53.7	55.2	56.4	56.3	55.7	54.4	53.5

6.4. Antenna pattern

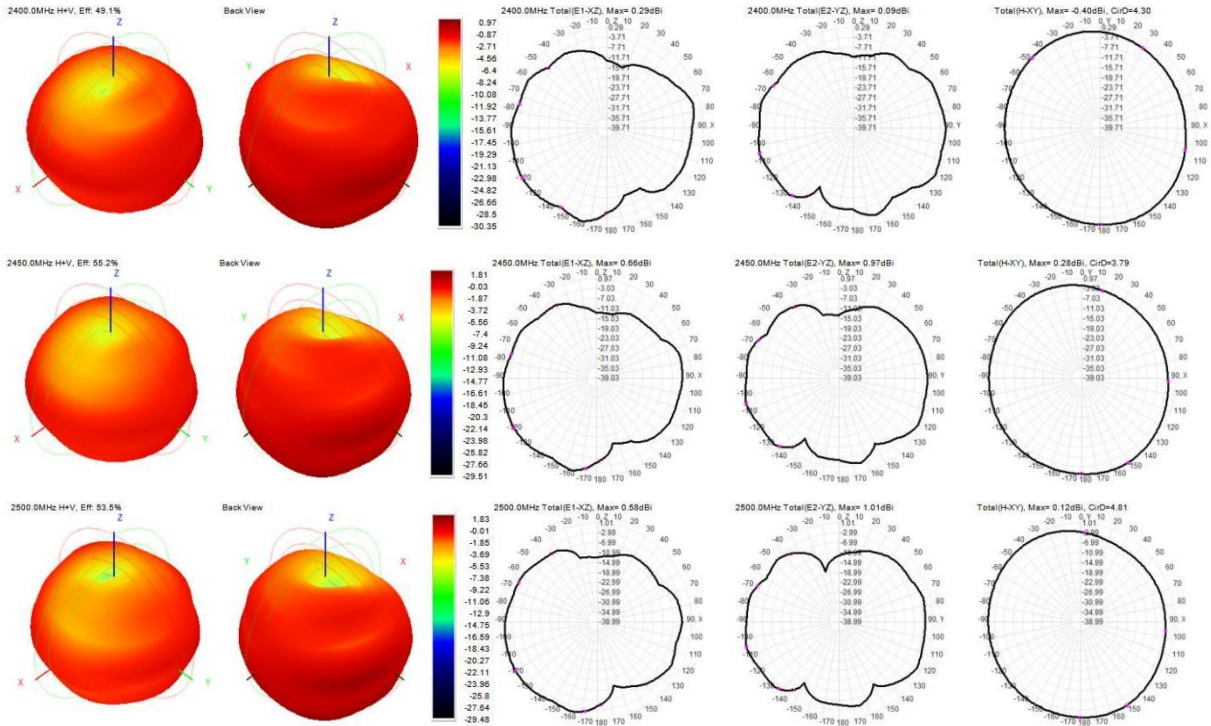

Figure 9 Antenna pattern

7. Design Guidance

7.1. Application Guide Circuit

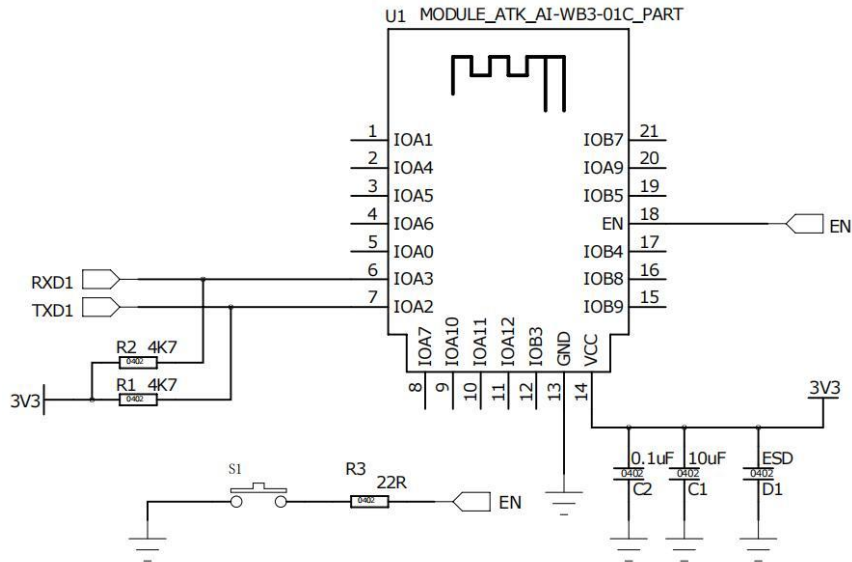

Figure 10 Application circuit diagram

- If the IO port is used as PWM, it is recommended to reserve a 4.7K pull-down resistor around the module. Especially in the application of light control, it can prevent the phenomenon of flashing lights at the moment of power-on and start-up.

7.2. Recommend PCB footprint size

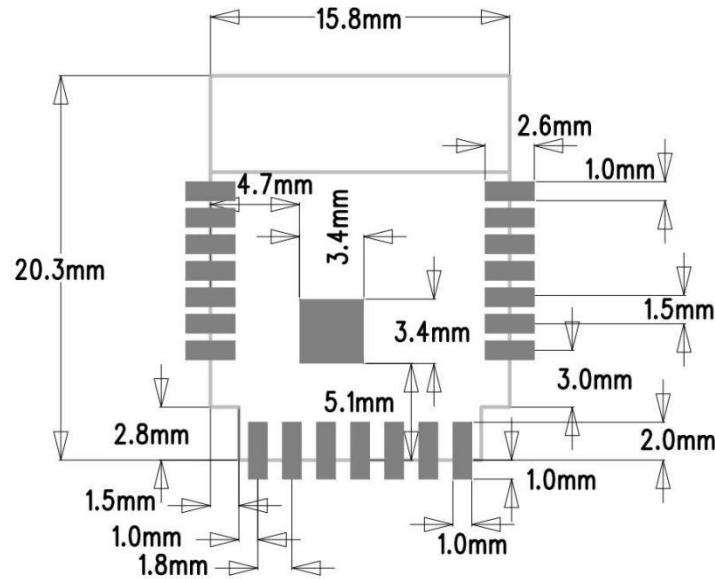

Figure 11 Recommend PCB footprint size(unit:mm)

7.3. Antenna layout requirements

- For the installation position on the motherboard, the following two methods are recommended:

Solution 1: Put the module on the edge of the motherboard, and the antenna area extends out of the edge of the motherboard.

Solution 2: Put the module on the edge of the motherboard, and hollow out an area on the edge of the motherboard where the antenna is.

- In order to meet the performance of the on-board antenna, it is forbidden to place metal parts around the antenna and keep away from high-frequency devices.

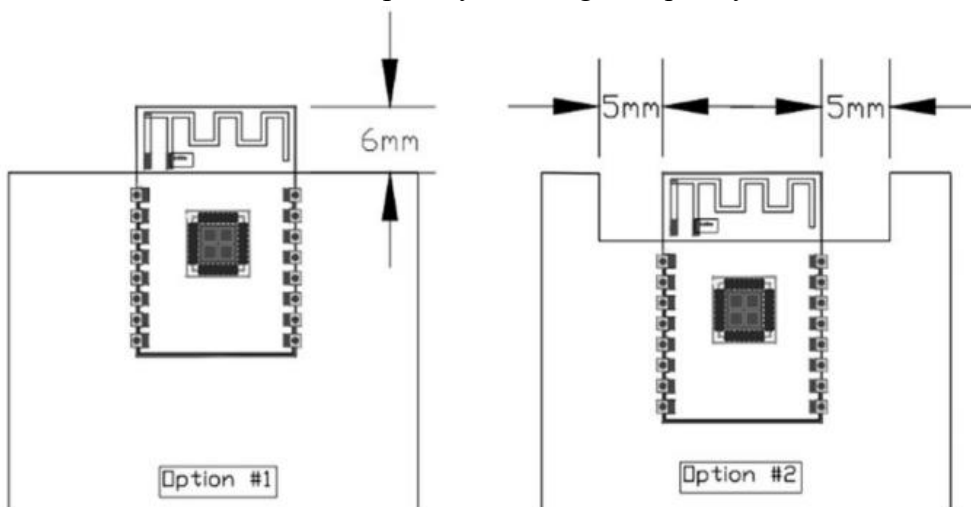

Figure 12 Antenna layout diagram

7.4. Power supply

- Recommend 3.3V voltage, peak current above 500mA.
- It is recommended to use LDO power supply; if using DC-DC, it is recommended to control the ripple within 30mV.
- It is recommended to reserve the position of the dynamic response capacitor for the DC-DC power supply circuit, which can optimize the output ripple when the load changes greatly.
- It is recommended to add ESD devices to the 3.3V power interface

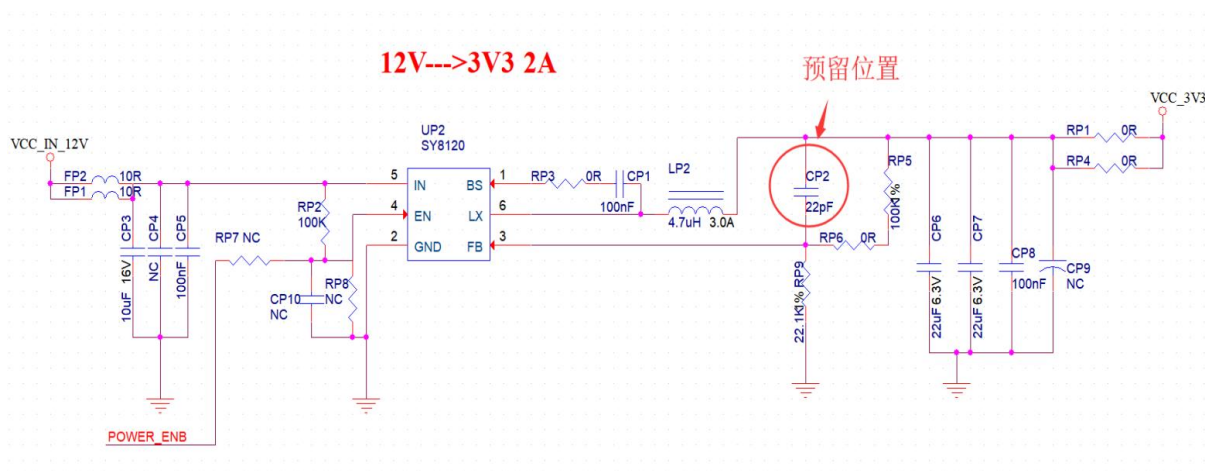

Figure 13 DC-DC step-down circuit diagram

7.5. GPIO

- There are some IO ports on the periphery of the module. If you need to use it, it is recommended to connect a 10-100 ohm resistor in series with the IO ports. This can suppress overshoot and make the levels on both sides more stable. Helpful for both EMI and ESD.
- For the pull-up and pull-down of the special IO port, please refer to the instructions in the specification, which will affect the startup configuration of the module.
- The IO port of the module is 3.3V. If the level of the main control and the IO port of the module do not match, a level conversion circuit needs to be added.
- If the IO port is directly connected to the peripheral interface, or terminals such as pin headers, it is recommended to reserve an ESD device near the IO port wiring near the terminal.

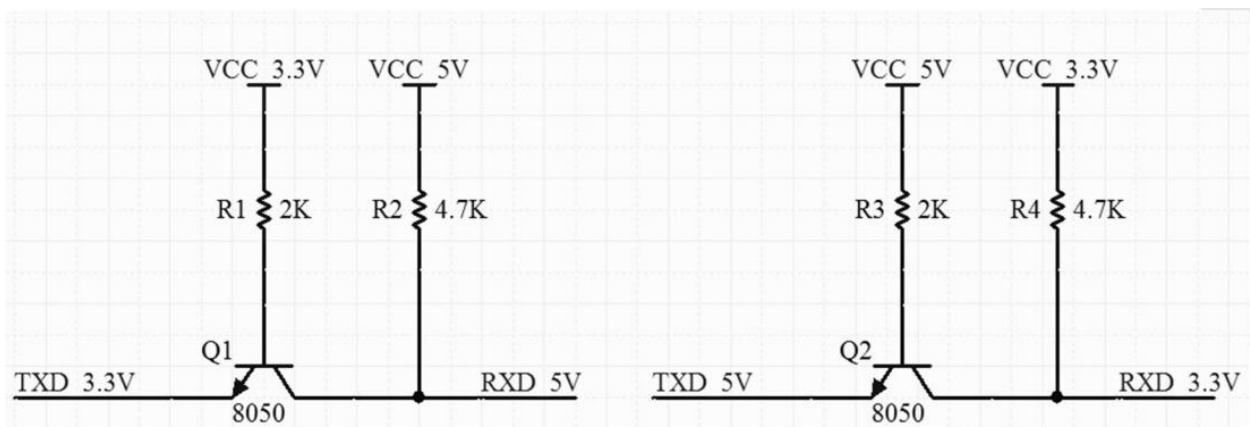

Figure 14 Level convert circuit

8. Storage conditions

Products sealed in moisture-proof bags should be stored in a non-condensing atmosphere at $<40^{\circ}\text{C}/90\%\text{RH}$.

The moisture sensitivity level MSL of the module is 3.

After the vacuum bag is unpacked, it must be used within 168 hours at $25 \pm 5^{\circ}\text{C}/60\%\text{RH}$, otherwise it needs to be baked before it can be put online again.

9. Reflow welding curve diagram

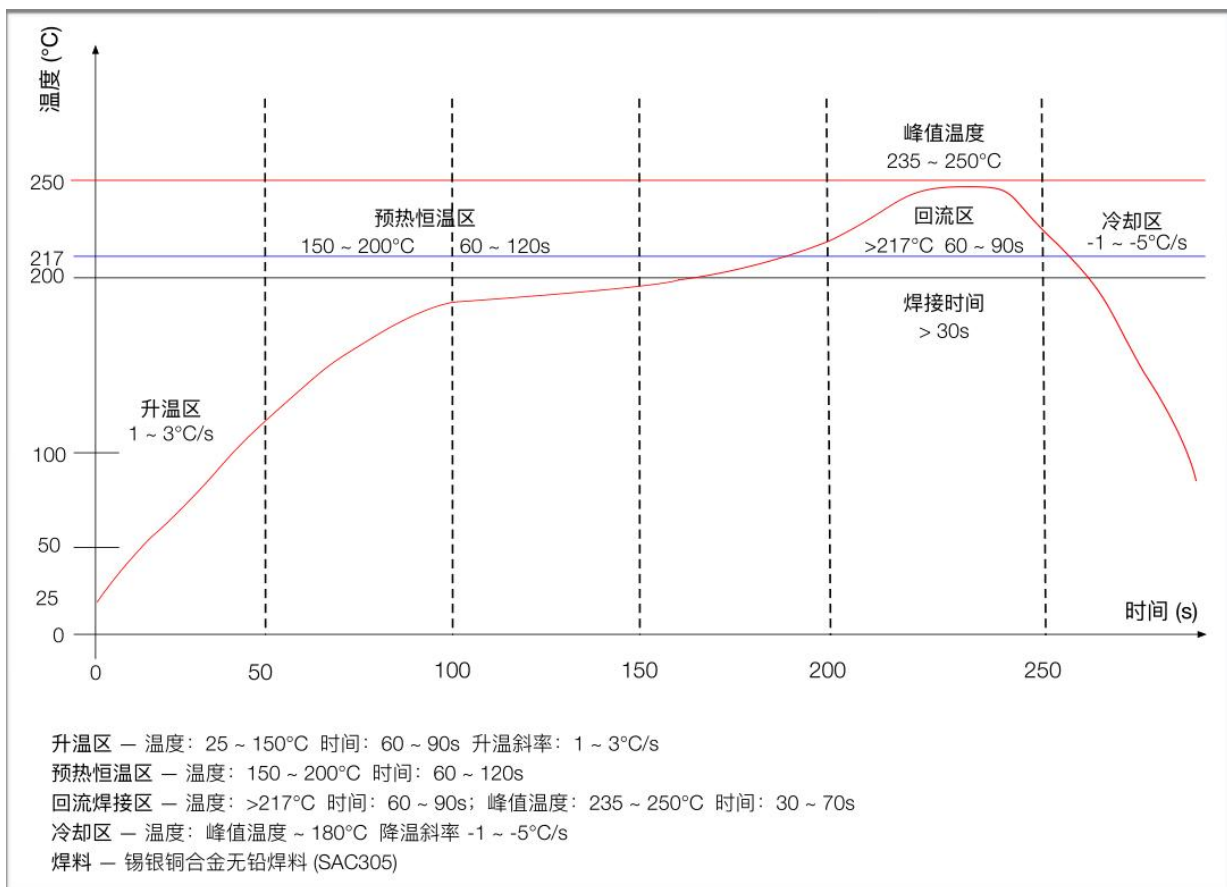

Figure 15 Reflow welding diagram

10. Product Packaging Information

Ai-WB3-01C module was packaged in a tape, 900pcs/reel.As shown in the below image:



Figure 16 Package and packing diagram

11.Contact us

[Ai-Thinker official website](#)

[Office forum](#)

[Develop DOCS](#)

[LinkedIn](#)

[Tmall shop](#)

[Taobao shop](#)

[Alibaba shop](#)

[Technical support email: support@aithinker.com](mailto:support@aithinker.com)

[Domestic business cooperation: sales@aithinker.com](mailto:sales@aithinker.com)

[Overseas business cooperation: overseas@aithinker.com](mailto:overseas@aithinker.com)

Company Address: Room 403,408-410, Block C, Huafeng Smart Innovation Port, Gushu 2nd Road, Xixiang, Baoan District, Shenzhen.

Tel: +86-0755-29162996



WeChat mini program



WeChat official account

Disclaimer and copyright notice

The information in this article, including the URL address for reference, is subject to change without notice.

The document is provided "as is" without any guarantee responsibility, including any guarantee for merchantability, suitability for a specific purpose, or non-infringement, and any guarantee mentioned elsewhere in any proposal, specification or sample. This document does not bear any responsibility, including the responsibility for infringement of any patent rights arising from the use of the information in this document. This document does not grant any license for the use of intellectual property rights in estoppel or other ways, whether express or implied.

The test data obtained in the article are all obtained from Ai-Thinker's laboratory tests, and the actual results may vary slightly.

All brand names, trademarks and registered trademarks mentioned in this article are the property of their respective owners, and it is hereby declared.

The final interpretation right belongs to Shenzhen Ai-Thinker Technology Co., Ltd.

Notice

Due to product version upgrades or other reasons, the contents of this manual may be changed.

Shenzhen Ai-Thinker Technology Co., Ltd. reserves the right to modify the contents of this manual without any notice or prompt.

This manual is only used as a guide. Shenzhen Ai-Thinker Technology Co., Ltd. makes every effort to provide accurate information in this manual. However, Shenzhen Ai-Thinker Technology Co., Ltd. does not guarantee that the contents of the manual are completely free of errors. All statements and information in this manual And the suggestion does not constitute any express or implied guarantee.