



Ai-WB1-32S-CAM Specification

Version V1.2.0

Copyright ©2022

Content

1. Product Overview	4
1.1. Characteristic	5
2. Main parameters	6
2.1. Power supply selection	6
2.2. Static electricity requirements	6
2.3. Electrical characteristics	7
2.4. WiFi RF performance	7
2.5. BLE RF performance	8
2.6. Single module power consumption	8
3. Appearance size	9
4. Indicator light and button description	10
5. Pin definition	11
6. Schematic diagram	13
7. Product packaging information	14
8. Contact us	14
Disclaimer and copyright notice	15
Notice	15

1. Product Overview

Ai-WB1-32S-CAM is a camera development board developed by Shenzhen Ai-Thinker Technology Co., Ltd. for Ai-WB1-32S module + GC032A camera. The development board is equipped with W800 chip as the core processor and supports Wi-Fi 802.11b /g/n protocol and BLE 4.2 protocol. W800 chip has built-in low-power 32-bit XT804 CPU, operating frequency of 240MHz, built-in 2MB Flash, 288KB RAM and rich peripheral interfaces, including PSRAM, SPI, UART, I2C, PWM, ADC, Touch Senser, Duplex I2S and GPIO, etc.

Ai-WB1-32S-CAM can be widely used in various IoT applications, suitable for home smart device image transmission, wireless industrial control, wireless monitoring and other IoT applications, is an ideal solution for IoT applications.

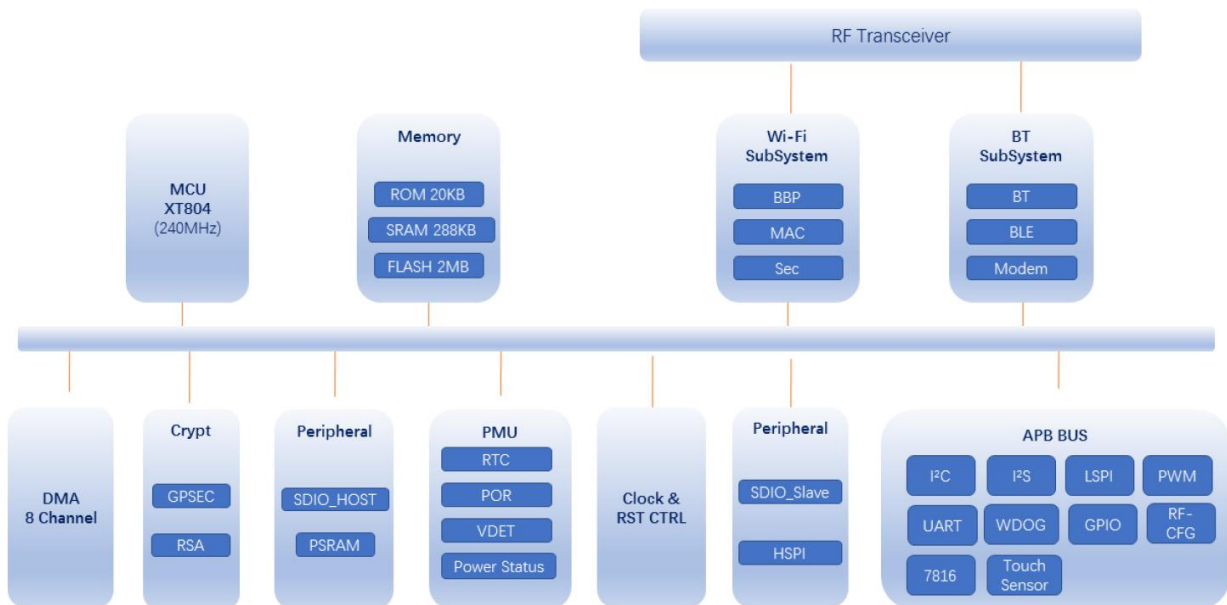

Figure 1 W800 Main chip architecture diagram

1.1. Characteristic

- Package: DIP-16
- Support IEEE 802.11 b/g/n protocol
- Wi-Fi security supports Wi-Fi WMM/WMM-PS/WPA/WPA2 /WPS
- Supports 20/40MHz bandwidth with a maximum speed of 150 Mbps
- Support BLE working mode, support BLE4.2 protocol
- Support Station , Station + SoftAP , SoftAP mode
- Support 32-bit XT804 CPU, 288KB RAM
- MCU has built-in Tee security engine, and the code can distinguish security events from non-security events
- Integrated SASC/TIPC, memory and internal modules/interfaces can be configured with security attributes to prevent unsafe code access
- Enable firmware signature mechanism for secure Boot/upgrade
- With firmware encryption function to enhance code security
- Firmware encryption keys are distributed using asymmetric algorithms for enhanced key security
- Hardware encryption module: RC4256, AES128, DES/3DES, SHA1/MD5, CRC32, 2048RSA, true random number generator
- Integrated Wi-Fi MAC/BB/RF/PA/LNA/Bluetooth
- Supports secondary development and integrates Windows and Linux development environments

2. Main parameters

Table 1 main parameters

Model	Ai-WB1-32S-CAM
Package	DIP-16
Size	40.01*27.01(±0.2)mm
Antenna	On-Board antenna
Operation temperature	-40 °C ~ 85 °C
Storage environment	-40 °C ~ 125 °C , < 90%RH
Power supply	Supply voltage 3.3V or 5V, current > 500mA
Interfaces	UART/PWM/I2C
IO	2
Serial port rate	Support 110~2000000bps , default 115200 bps
Bluetooth	BLE 4.2
Security	Wi-Fi WMM/WMM-PS/WPA/WPA2 /WPS
Flash	Default 2MByte
RAM	Internal 288KB + External 8MB
Image output format	JPEG
Resolution	Maximum support 320*240

2.1. Power supply selection

Ai-WB2-32S-CAM supports three power supply modes:

- 5V and GND pin power supply
- 3V3 and GND pin power supply

2.2. Static electricity requirements

Ai-WB1-32S-CAM is electrostatic sensitive equipment, special precautions should be taken during handling.



Figure 2 ESD anti-static diagram

2.3. Electrical characteristics

Table 2 Electrical Characteristics Table

Parameter		Condition	Min.	Typical value	Max.	Unit
Power supply		3V3/VDD	3.0	3.3	3.6	V
		5V	4.75	5.0	5.25	V
I/O	VIL	-	-0.3	-	0.8	V
	VIH	-	2.0	-	VDD+0.3	V
	VOL	-	-	-	0.4	V
	VOH	-	2.4	-	-	V
	IMAX	-	-	-	24	mA

2.4. WiFi RF performance

Table 3 Wi-Fi RF performance table

Description	Typical value			Unit
Spectrum Range	2400 ~ 2483.5MHz			MHz
Output power				
Model	Min.	Typical value	Max.	Unit
11n mode HT20, PA output power	-	12	-	dBm
In 11g mode, PA output power	-	13	-	dBm
In 11b mode, PA output power	-	18	-	dBm
Receiving sensitivity				
Model	Min.	Typical value	Max.	Unit
11b, 1 Mbps	-	-95	-	dBm
11b, 11 Mbps	-	-85	-	dBm
11g, 6 Mbps	-	-89	-	dBm
11g, 54 Mbps	-	-72	-	dBm
11n, HT20 (MCS7)	-	-69	-	dBm

2.5. BLE RF performance

Table 4 BLE RF performance table

Description	Typical value			Unit
Spectrum Range	2400 ~ 2483.5MHz			MHz
Output power				
Rate Mode	Min.	Typical value	Max.	Unit
1Mbps	-	4	6	dBm
Receiving sensitivity				
Rate Mode	Min.	Typical value	Max.	Unit
1Mbps sensitivity@30.8%PER	-	-92	-	dBm

2.6. Single module power consumption

The following power consumption figures are based on a single module 3.3V power supply, 25° C ambient temperature, and are measured using the internal voltage regulator.

- All measurements are made at the antenna interface with filters.
- All transmit data is based on 100% duty cycle, measured in continuous transmit mode.

Table 5 Power Consumption Table

Model	Minimum	Average	Maxim	Unit
Tx 802.11b, 11Mbps, POUT=+19dBm	-	348	-	mA
Tx 802.11g, 54Mbps, POUT =+15dBm	-	190	-	mA
Tx 802.11n, MCS7, POUT =+12dBm	-	190	-	mA
Rx 802.11b, 1024 bytes long	-	96	-	mA
Rx 802.11g, 1024 bytes long	-	96	-	mA
Rx 802.11n, 1024 bytes long	-	96	-	mA
Standby current	-	20	-	μA

3. Appearance size

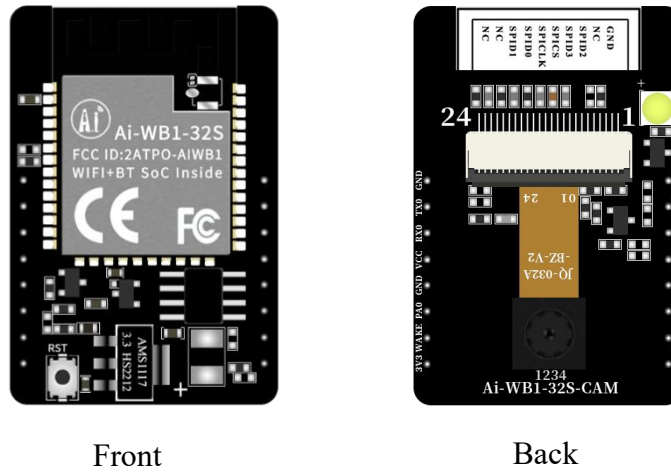

Figure 3 Appearance drawing (the picture and silk screen are for reference only, the actual product shall prevail)

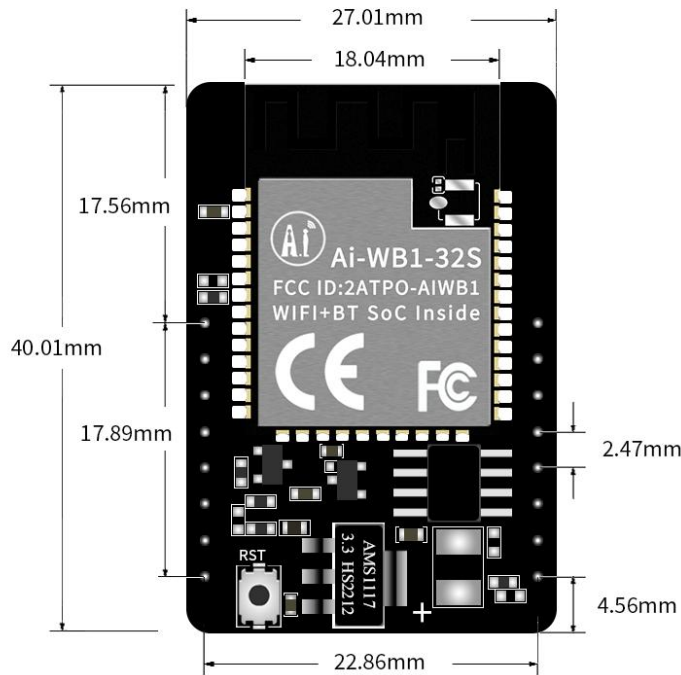

Figure 4 Dimensions

4. Indicator light and button description

Ai-WB1-32S-CAM is also connected to the indicator light, and leads to the RST (reset button) key, as shown in the following figure:

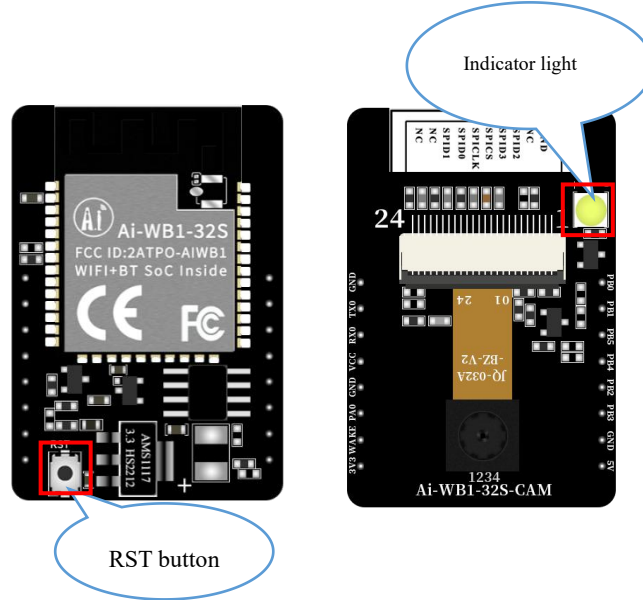

Figure 5 Schematic diagram of indicator lights and buttons

Table 6 Indicator/key IO correspondence table

Device	Function	GPIO
RST button	Reset button	RST
Indicator light	The light is always on when the video stream is turned on, and the light is off when the video stream is turned off.	PA4
	Blinks when taking pictures	

Note: The development board needs to pull down PA0 to enter the programming mode.

5. Pin definition

Ai-WB1-32S-CAM has a total of 16 interfaces, such as the pin diagram, the pin function definition table is the interface definition.

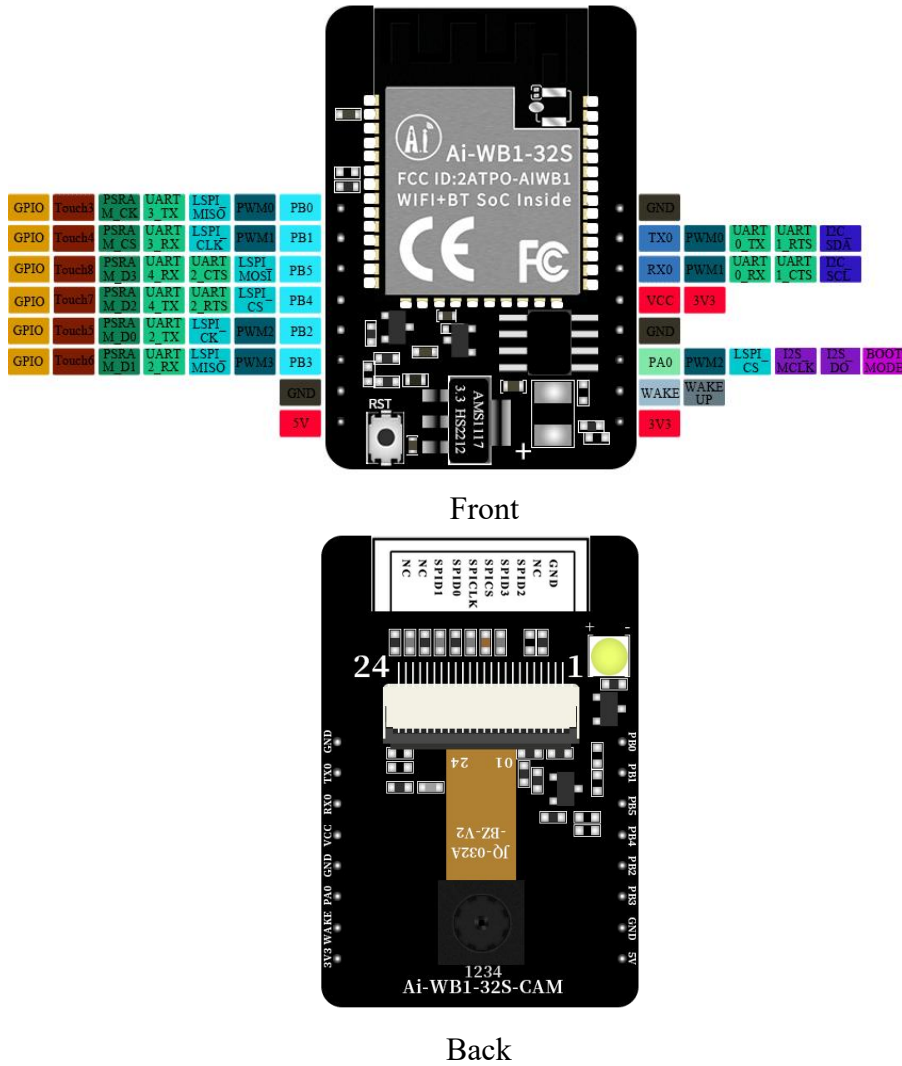

Figure 6 pin diagram

Table 7 Definition table of pin functions

No.	Name	Function
1	PB0	This IO port is already occupied by the external PSRAM of the development board, and it is not recommended to use it. If you need to use it, please contact Ai-Thinker. PWM0/LSPI_MISO/UART3_TX/PSRAM_CK/Touch3/GPIO
2	PB1	This IO port is already occupied by the external PSRAM of the development board, and it is not recommended to use it. If you need to use it, please contact Ai-Thinker. PWM1/LSPI_CLK/UART3_RX/PSRAM_CS/Touch4/GPIO
3	PB5	This IO port is already occupied by the external PSRAM of the development board, and it is not recommended to use it. If you need to use it, please contact Ai-Thinker. LSPI_MOSI/UART2_CTS/UART4_RX/PSARM_D3/Touch8/GPIO
4	PB4	This IO port is already occupied by the external PSRAM of the development board, and it is not recommended to use it. If you need to use it, please contact Ai-Thinker. LSPI_CS/UART2_RTS/UART4_TX/PSRAM_D2/Touch7/GPIO
5	PB2	This IO port is already occupied by the external PSRAM of the development board, and it is not recommended to use it. If you need to use it, please contact Ai-Thinker. PWM2/LSPI_CK/UART2_TX/PSRAM_D0/Touch5/GPIO
6	PB3	This IO port is already occupied by the external PSRAM of the development board, and it is not recommended to use it. If you need to use it, please contact Ai-Thinker. PWM3/LSPI_MISO/UART2_RX/PSRAM_D1/Touch6/GPIO
7	GND	Ground
8	5V	5V power supply
9	3V3	3.3V power supply
10	WAKE	WAKEUP function
11	PA0	The internal circuit of the development board has occupied this IO port and cannot be used I2S_MCLK/LSPI_CS/PWM2/I2S_DO/BOOTMODE
12	GND	Ground
13	VCC	3.3V power supply
14	RX0	UART0_RX/PWM1/UART1_CTS/I2C_SCL
15	TX0	UART0_TX/PWM0/UART1_RTS/I2C_SDA
16	GND	Ground

6. Schematic diagram

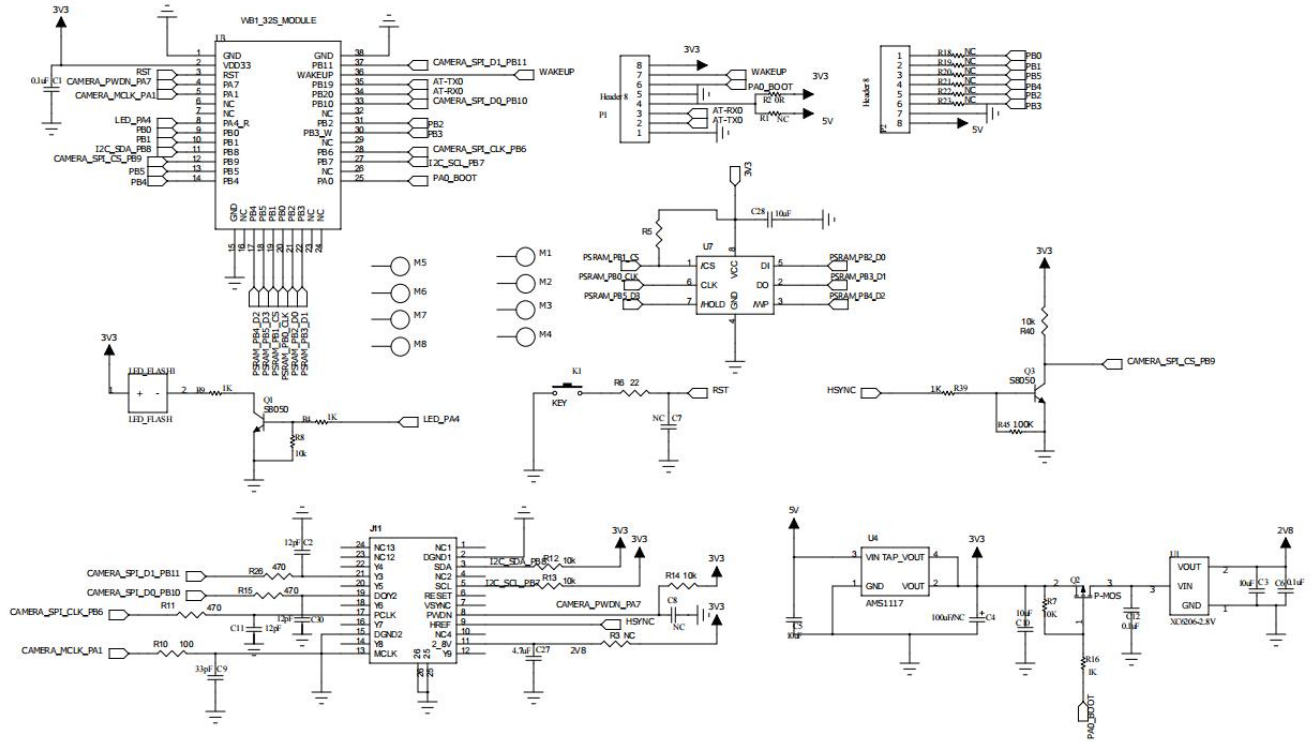

Figure 7 schematic diagram

7. Product packaging information

Table 8 packing information table

Packing List	Packaging method	Per package (Electrostatic bag)	Per package (Sealed bag)
Ai-WB1-32S-CAM	Foam+ Electrostatic bag	1pcs	20pcs

8. Contact us

[Ai-Thinker official website](#)

[Official Forum](#)

[Develop DOCS](#)

[LinkedIn](#)

[Tmall shop](#)

[Taobao shop](#)

[Alibaba shop](#)

Technical support Email: support@aithinker.com

Domestic business cooperation: sales@aithinker.com

Overseas business cooperation: overseas@aithinker.com

Company address: Room 403,408-410, Block C, Huafeng Smart Innovation Port, Gushu 2nd Road, Xixiang, Baoan District, Shenzhen.

Tel: 0755-29162996



WeChat mini program



WeChat official account

Disclaimer and copyright notice

The information in this article, including the URL address for reference, is subject to change without notice.

The document is provided "as is" without any guarantee responsibility, including any guarantee for merchantability, suitability for a specific purpose, or non-infringement, and any guarantee mentioned elsewhere in any proposal, specification or sample. This document does not bear any responsibility, including the responsibility for infringement of any patent rights arising from the use of the information in this document. This document does not grant any license for the use of intellectual property rights in estoppel or other ways, whether express or implied.

The test data obtained in the article are all obtained from Ai-Thinker's laboratory tests, and the actual results may vary slightly.

All brand names, trademarks and registered trademarks mentioned in this article are the property of their respective owners, and it is hereby declared.

The final interpretation right belongs to Shenzhen Ai-Thinker Technology Co., Ltd.

Notice

Due to product version upgrades or other reasons, the contents of this manual may be changed.

Shenzhen Ai-Thinker Technology Co., Ltd. reserves the right to modify the contents of this manual without any notice or prompt.

This manual is only used as a guide. Shenzhen Ai-Thinker Technology Co., Ltd. makes every effort to provide accurate information in this manual. However, Shenzhen Ai-Thinker Technology Co., Ltd. does not guarantee that the contents of the manual are completely free of errors. All statements and information in this manual. And the suggestion does not constitute any express or implied guarantee.